

CAE 465/526 Building Energy Conservation Technologies

Fall 2023

September 28, 2023

Model Calibration and Uncertainty Analysis

Built
Environment
Research

@ IIT



*Advancing energy, environmental, and
sustainability research within the built environment*

www.built-envi.com

Dr. Mohammad Heidarinejad, Ph.D., P.E.
Civil, Architectural and Environmental Engineering
Illinois Institute of Technology

muh182@iit.edu

ANNOUNCEMENT

Announcement

- Assignment 3 is due tomorrow night
- Assignment 4 is due next Friday
- How was the career fair?

Announcement

- Check out the GitHub repositories:

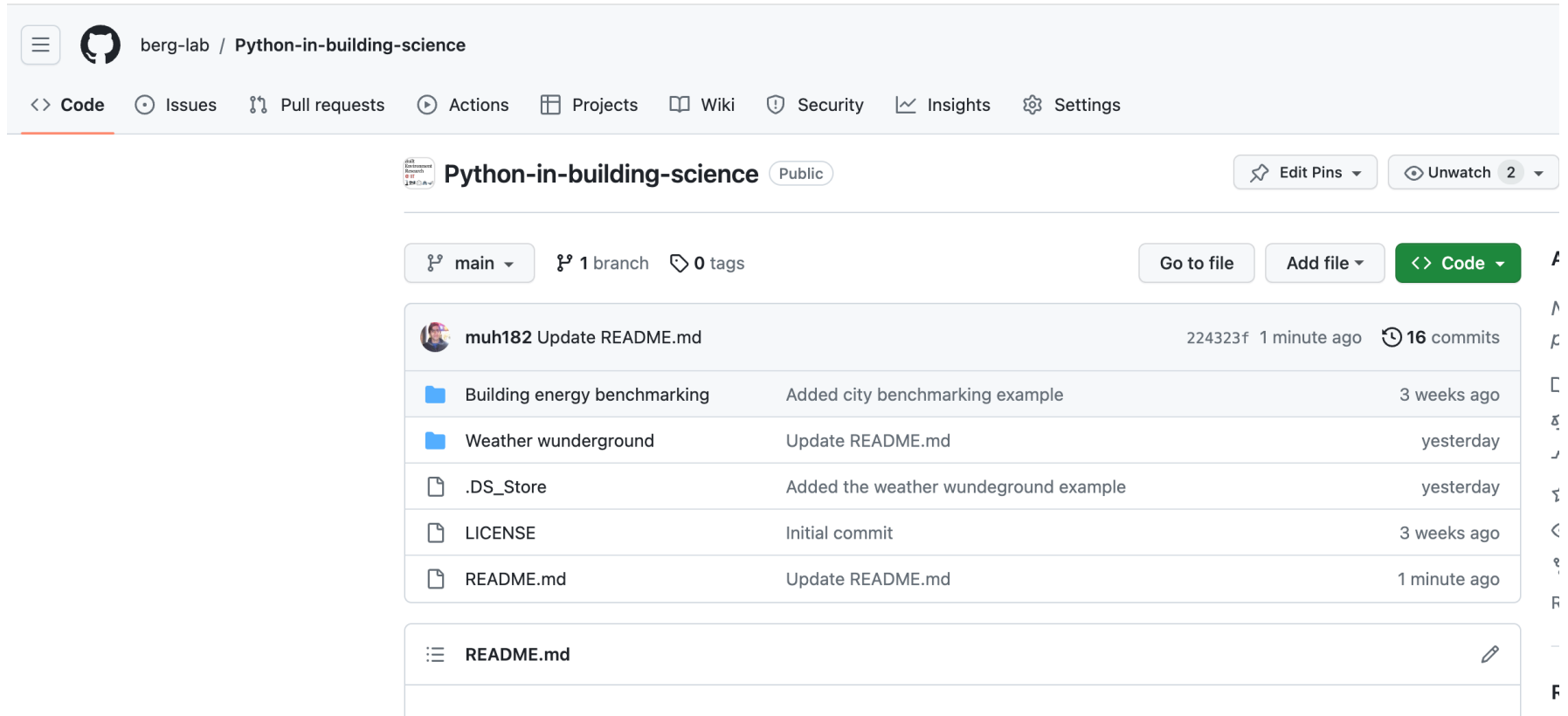

The screenshot shows the GitHub interface for the repository 'Python-in-building-science' by 'berg-lab'. The repository is public and has 16 commits. The main branch is selected. The commit history shows the following files and their commit dates:

File	Commit Message	Commit Date
Building energy benchmarking	Added city benchmarking example	3 weeks ago
Weather wunderground	Update README.md	yesterday
.DS_Store	Added the weather wundeground example	yesterday
LICENSE	Initial commit	3 weeks ago
README.md	Update README.md	1 minute ago

The repository also has a README.md file, which is currently selected in the file browser.

<https://github.com/berg-lab/Python-in-building-science/tree/main>

Announcement

- Check out the GitHub repositories:

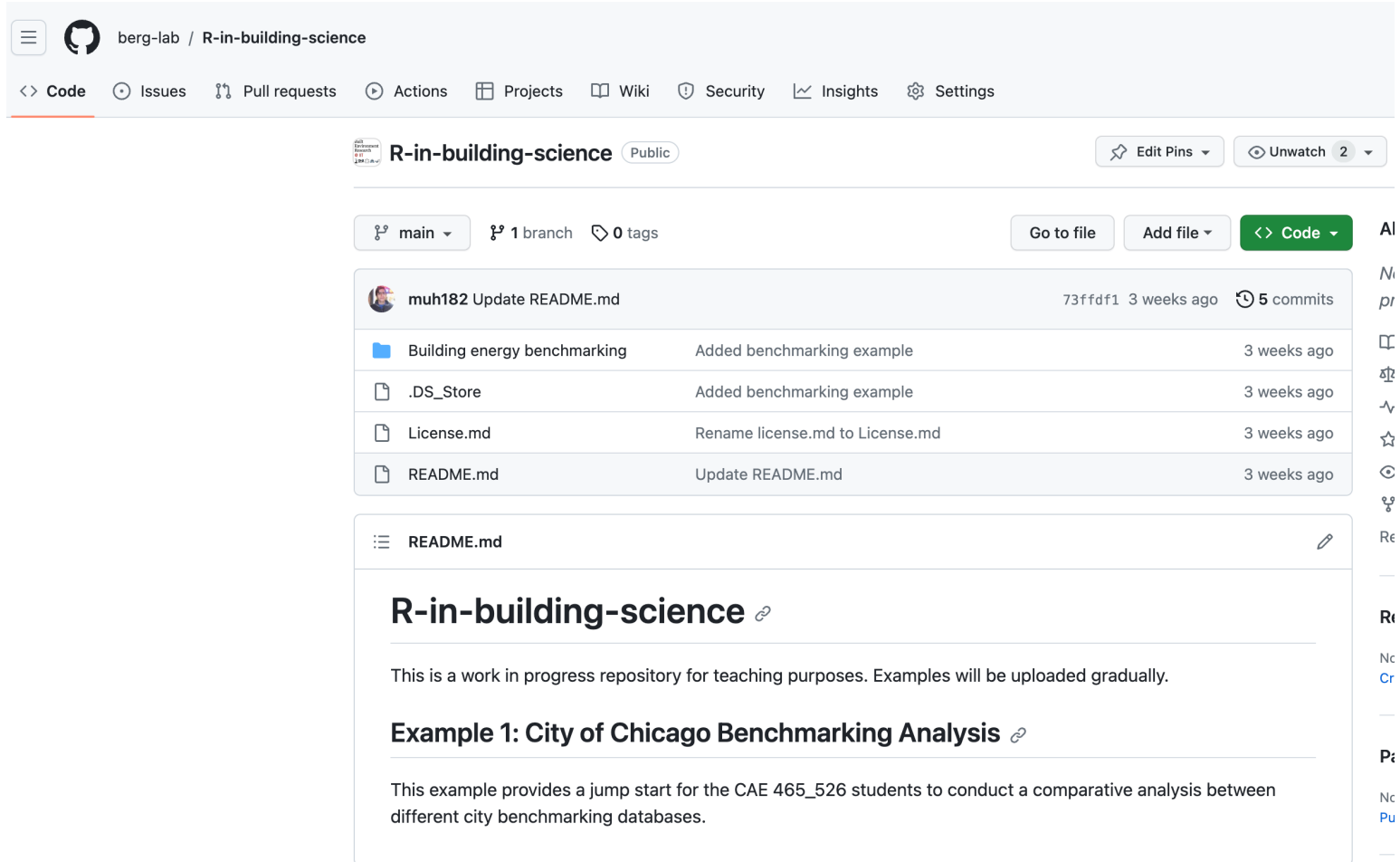

The screenshot shows the GitHub repository page for 'berg-lab / R-in-building-science'. The repository is public and has 1 branch (main) and 0 tags. The commit history shows a recent update to the README.md file by user 'muh182' 3 weeks ago, with 5 commits. The repository contains files for 'Building energy benchmarking', '.DS_Store', 'License.md', and 'README.md'. The README.md file is displayed, containing the following text:

R-in-building-science

This is a work in progress repository for teaching purposes. Examples will be uploaded gradually.

Example 1: City of Chicago Benchmarking Analysis

This example provides a jump start for the CAE 465_526 students to conduct a comparative analysis between different city benchmarking databases.

<https://github.com/berg-lab/R-in-building-science>

ENERGYPLUS / OPENSTUDIO (NODES)

EnergyPlus Nodes

3 Zone Dual Duct System

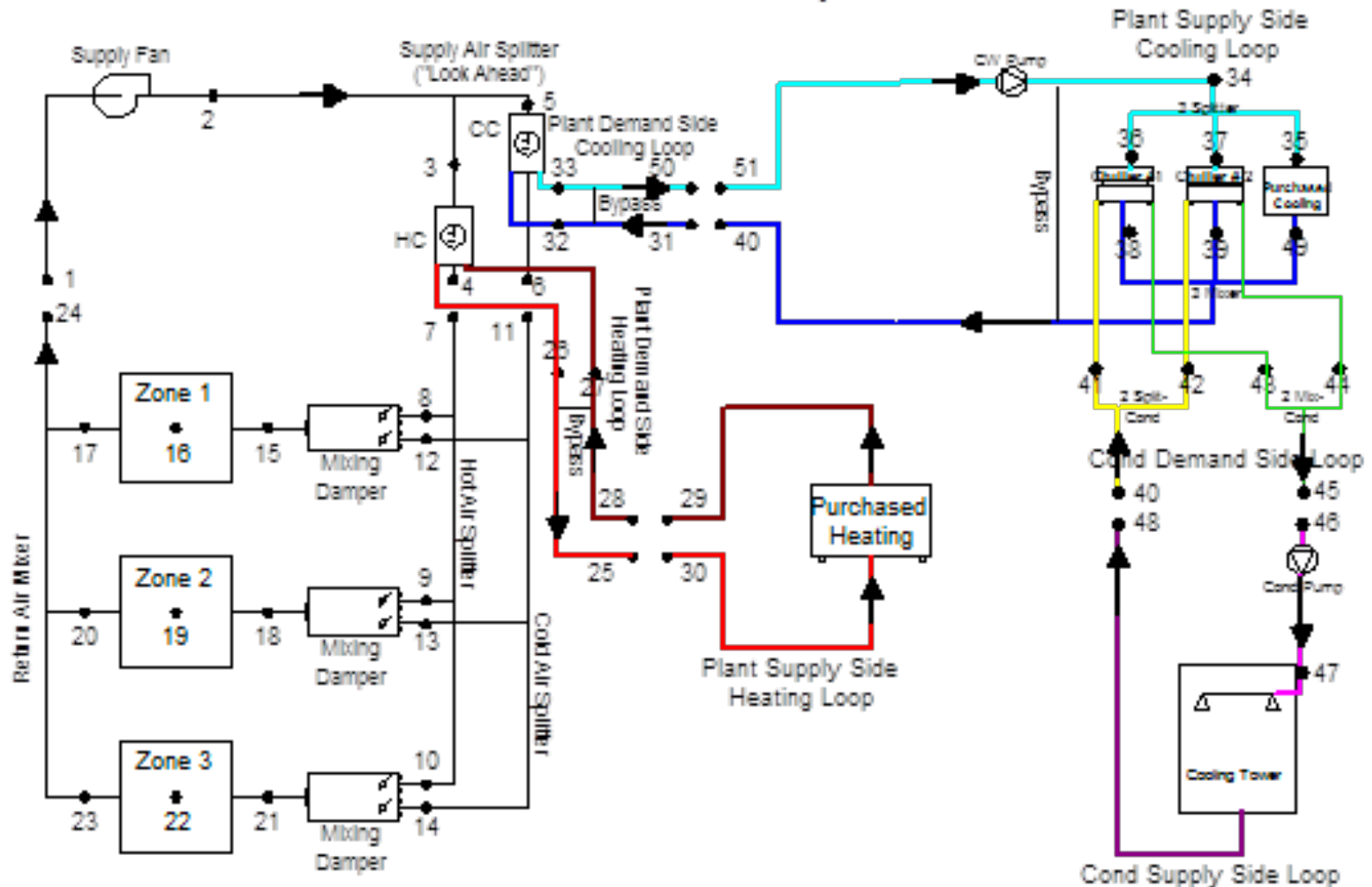

EnergyPlus Nodes

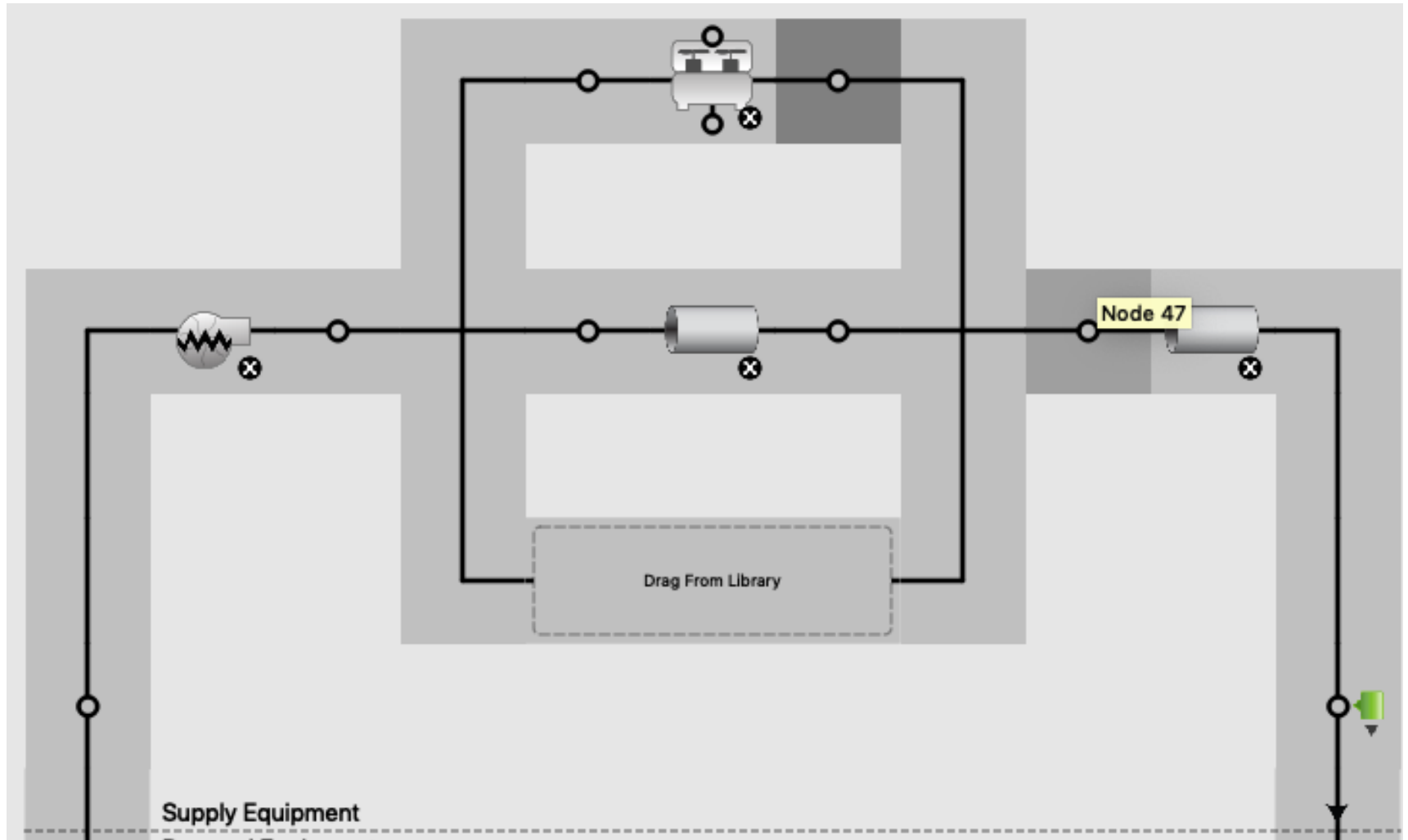

EnergyPlus Nodes

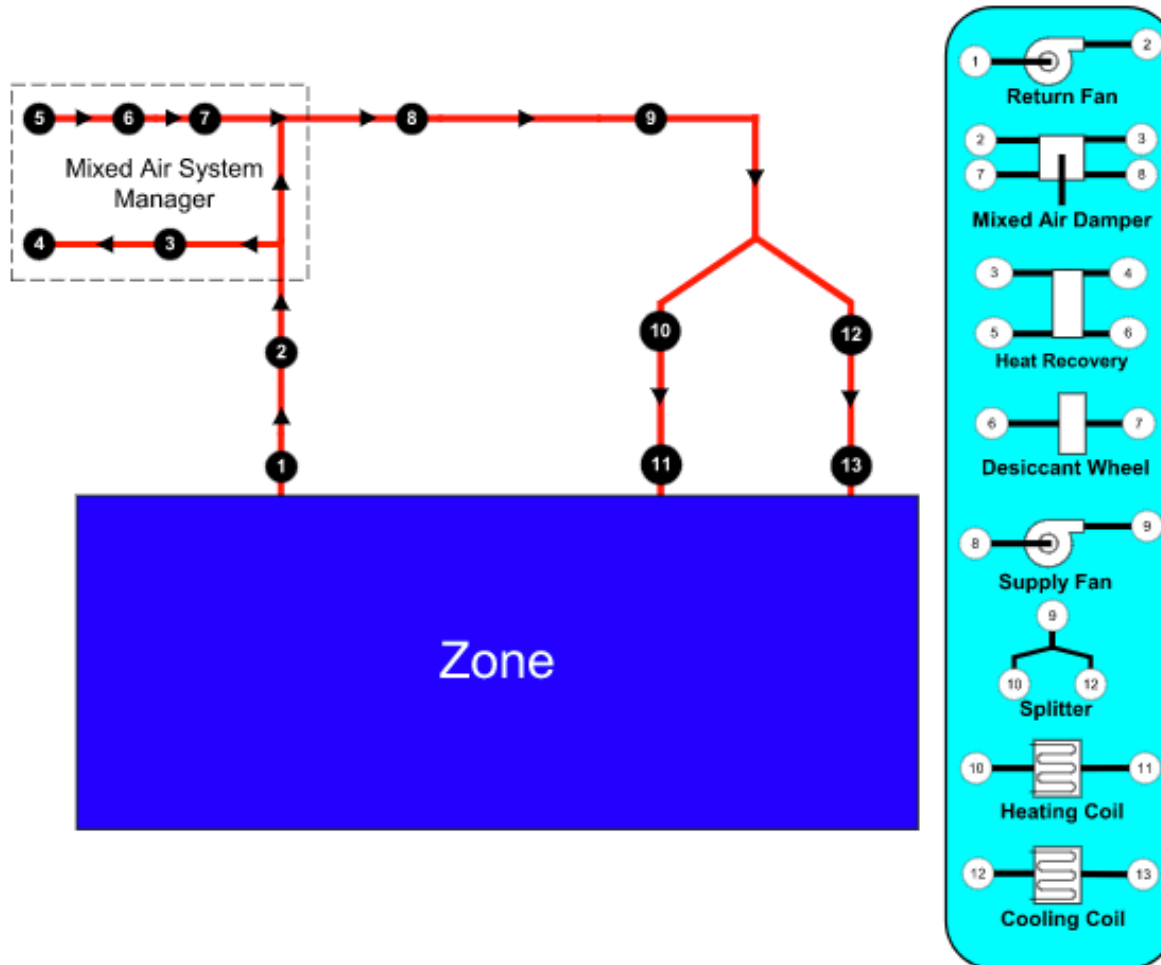

https://www.energyplus.net/sites/default/files/docs/site_v8.3.0/InputOutputReference/01b-InputOutputReference/index.html

EnergyPlus Nodes

```

??      ??      ?? ... curve output at rated conditions = 0.700
** Severe ** Node NODE 73 connects to no component
**      ~~~ ** Occurs in Supply Air Path=PACKAGED ROOFTOP VAV WITH REHEAT NODE 71 SUPPLY PATH
**      ~~~ ** Check the connection to a ZoneHVAC:EquipmentConnections object
**      ~~~ ** Check if this component is missing from the Supply Air Path
** Severe ** An outlet node in AirLoopHVAC="PACKAGED ROOFTOP VAV WITH REHEAT" is not connected to any zone
**      ~~~ ** Could not match ZoneEquipGroup Inlet Node="NODE 71" to any Supply Air Path or controlled zone
** Fatal  ** Preceding errors cause termination
...Summary of Errors that led to program termination:
..... Reference severe error count=2
..... Last severe error=An outlet node in AirLoopHVAC="PACKAGED ROOFTOP VAV WITH REHEAT" is not connected to any zone
***** Warning: Node connection errors not checked - most system input has not been read (see previous warning).
***** Fatal error -- final processing. Program exited before simulations began. See previous error messages.
*****

```

EnergyPlus Nodes

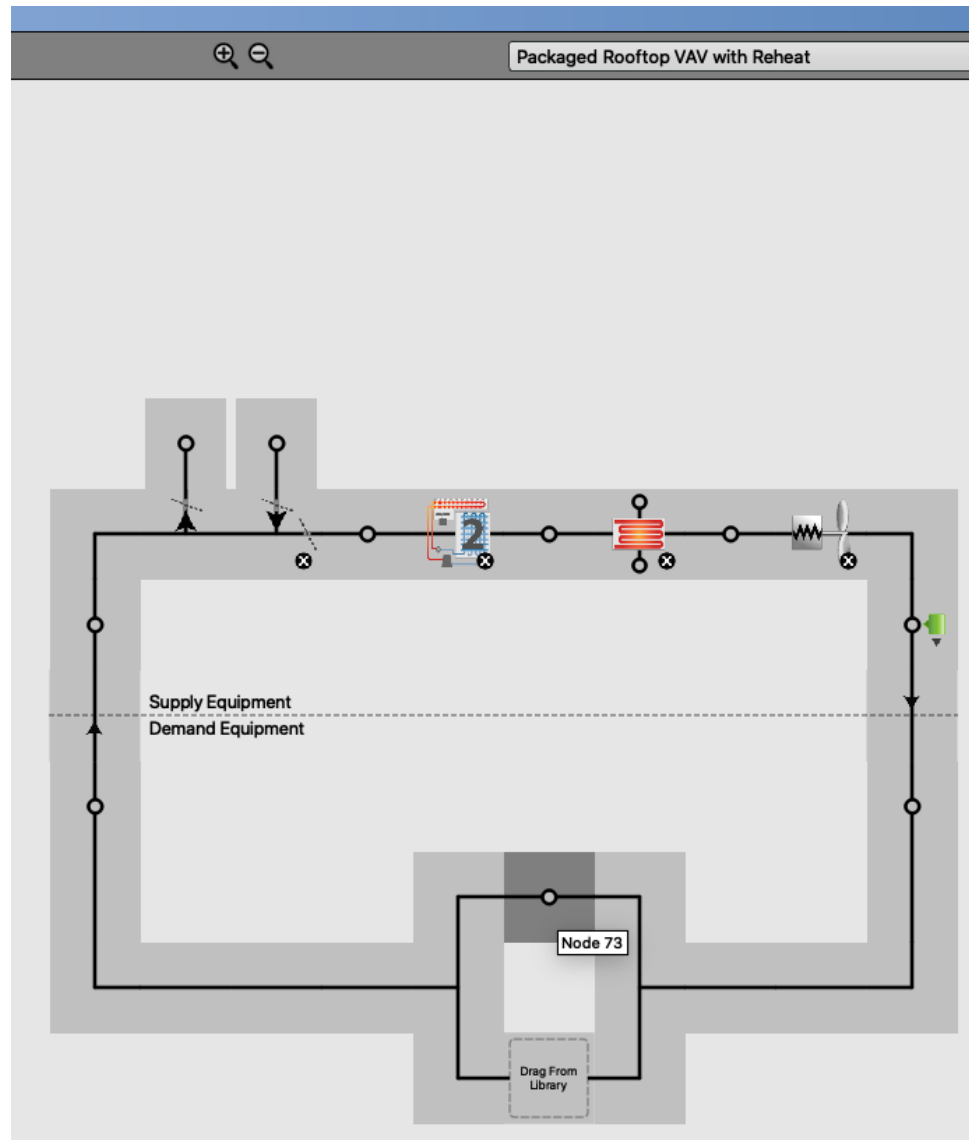





READ TIME SERIES AND MONTHLY DATA

Read Data

Measures

- ▼  **OpenStudio Measures**
 - Meter Elec*
 - Meter Ext L*
 - Add Hourly Meters*
 - Add SWH Loop*

▼ **Reporting** 6

- ▼ **QAQC** 6
 -  **BCL** Add Hourly Meters
 -  **BCL** Add Meter
 -  **BCL** Add Output Variable
 -  **BCL** ExportMetertoCSV
 -  **BCL** ExportVariabletoCSV
 -  **BCL** OpenStudio Results

Read Data

Table of Contents

[Top](#)

[Annual Building Utility Performance Summary](#)

[Input Verification and Results Summary](#)

[Demand End Use Components Summary](#)

[Source Energy End Use Components Summary](#)

[Component Sizing Summary](#)

[Surface Shadowing Summary](#)

[Adaptive Comfort Summary](#)

[Initialization Summary](#)

[Annual Heat Emissions Summary](#)

[Annual Thermal Resilience Summary](#)

[Climatic Data Summary](#)

[Envelope Summary](#)

[Shading Summary](#)

[Lighting Summary](#)

[Equipment Summary](#)

[HVAC Sizing Summary](#)

[Coil Sizing Details](#)

[System Summary](#)

[Outdoor Air Summary](#)

[Outdoor Air Details](#)

[Object Count Summary](#)

[Energy Meters](#)

[Sensible Heat Gain Summary](#)

[Standard 62.1 Summary](#)

[LEED Summary](#)

[Annual CO2 Resilience Summary](#)

[Annual Visual Resilience Summary](#)

Read Data

File Preferences Components & Measures Help

Measures

OpenStudio Measures

Add Meter

Drop Measure From Library to Create a New Always Run Measure

EnergyPlus Measures

Drop Measure From Library to Create a New Always Run Measure

Reporting Measures

OpenStudio Results

Drop Measure From Library to Create a New Always Run Measure

Library Edit

Name
Add Meter

Description
This measure adds an meter at the requested reporting frequency.

Modeler Description
The measure just passes in the string and does not validate that it is a proper meter name. It is up to the user to know this or to

Inputs
Enter Meter Name
Electricity:Facility
Reporting Frequency
hourly

Sync Project Measures with Library

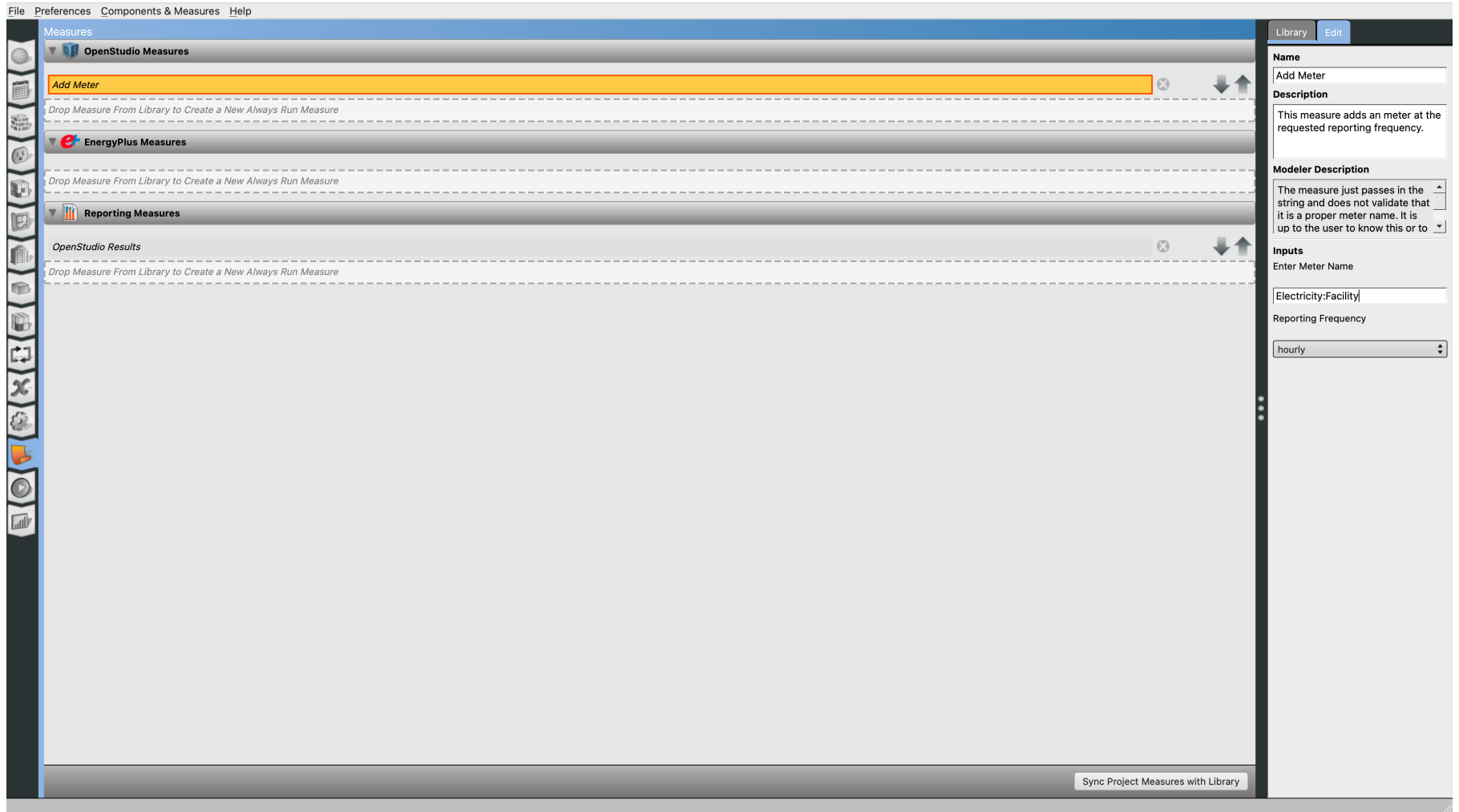
The screenshot displays the 'Measures' panel in a software application. On the left, there is a vertical toolbar with various icons. The main area is divided into three sections: 'OpenStudio Measures', 'EnergyPlus Measures', and 'Reporting Measures'. Each section contains a list of measures, with 'Add Meter' highlighted in yellow. A detailed view of the 'Add Meter' measure is shown on the right side, including its name, description, modeler description, and input fields for 'Enter Meter Name' and 'Reporting Frequency'. The 'Reporting Frequency' is currently set to 'hourly'. At the bottom right, there is a button labeled 'Sync Project Measures with Library'.

Read Data

```
eplusout.rdd
eplusout.rdd
1 ! Program Version,EnergyPlus, Version 23.1.0-87ed9199d4, YMD=2023.09.24 19:10,
2 ! Output:Variable Objects (applicable to this run)
3 Output:Variable,*,Site Outdoor Air Drybulb Temperature,hourly; !- Zone Average [C]
4 Output:Variable,*,Site Outdoor Air Dewpoint Temperature,hourly; !- Zone Average [C]
5 Output:Variable,*,Site Outdoor Air Wetbulb Temperature,hourly; !- Zone Average [C]
6 Output:Variable,*,Site Outdoor Air Humidity Ratio,hourly; !- Zone Average [kgWater/kgDryAir]
7 Output:Variable,*,Site Outdoor Air Relative Humidity,hourly; !- Zone Average [%]
8 Output:Variable,*,Site Outdoor Air Barometric Pressure,hourly; !- Zone Average [Pa]
9 Output:Variable,*,Site Wind Speed,hourly; !- Zone Average [m/s]
10 Output:Variable,*,Site Wind Direction,hourly; !- Zone Average [deg]
11 Output:Variable,*,Site Sky Temperature,hourly; !- Zone Average [C]
12 Output:Variable,*,Site Horizontal Infrared Radiation Rate per Area,hourly; !- Zone Average [W/m2]
13 Output:Variable,*,Site Diffuse Solar Radiation Rate per Area,hourly; !- Zone Average [W/m2]
14 Output:Variable,*,Site Direct Solar Radiation Rate per Area,hourly; !- Zone Average [W/m2]
15 Output:Variable,*,Liquid Precipitation Depth,hourly; !- Zone Sum [m]
16 Output:Variable,*,Site Precipitation Rate,hourly; !- Zone Average [m/s]
17 Output:Variable,*,Site Precipitation Depth,hourly; !- Zone Sum [m]
18 Output:Variable,*,Site Ground Reflected Solar Radiation Rate per Area,hourly; !- Zone Average [W/m2]
19 Output:Variable,*,Site Ground Temperature,hourly; !- Zone Average [C]
20 Output:Variable,*,Site Surface Ground Temperature,hourly; !- Zone Average [C]
21 Output:Variable,*,Site Deep Ground Temperature,hourly; !- Zone Average [C]
22 Output:Variable,*,Site Simple Factor Model Ground Temperature,hourly; !- Zone Average [C]
23 Output:Variable,*,Site Total Sky Cover,hourly; !- Zone Average []
24 Output:Variable,*,Site Opaque Sky Cover,hourly; !- Zone Average []
25 Output:Variable,*,Site Outdoor Air Enthalpy,hourly; !- Zone Average [J/kg]
26 Output:Variable,*,Site Outdoor Air Density,hourly; !- Zone Average [kg/m3]
27 Output:Variable,*,Site Solar Azimuth Angle,hourly; !- Zone Average [deg]
28 Output:Variable,*,Site Solar Altitude Angle,hourly; !- Zone Average [deg]
29 Output:Variable,*,Site Solar Hour Angle,hourly; !- Zone Average [deg]
30 Output:Variable,*,Site Rain Status,hourly; !- Zone Average []
31 Output:Variable,*,Site Snow on Ground Status,hourly; !- Zone Average []
Line: 1 Col: 1
```

Read Data



EnergyPlus timeseries visualization software

EnergyPlus has rich support for hourly and sub-hourly reporting, but as a model becomes larger and more complex, the simulation output size can become unwieldy for many existing tools. This can result in prohibitively long load-times just to view your simulation results.

Timestep attempts to be a better solution, offering a clean, user-friendly and near-instantaneous querying interface, as well as modern data visualization capabilities. It accomplishes this by using the EnergyPlus SQLite Output reporting, and can load and visualize very large simulation output files in seconds, rather than minutes.

Current Timestep features:

- Native support and install packages for MacOS and Windows.
- Heatmap, Multi-Line, Scatter Plot, Histogram, and Statistical Summary outputs
- CSV and clipboard export
- Saved sessions and multiple views within a session
- Support for multiple simulation files
- Auto-detection and parsing of BND files for more contextual IP units conversion.

Planned Timestep features:

- Support for ESO files as well as SQLite Outputs
- Support for platform-agnostic CSV files
- Support for tabular data (similar to eplusout.html reports)
- Additional chart types like 2D hexbins, scatter matrices, and box/violin distribution plots

Install and Setup

1. Download the current build for [Mac](#) or [PC](#).
2. (Optional): Download the [sample SQL file](#).
3. Unzip the file and place it in its own directory.
4. Double-click "timestep" (timestep.exe on Windows)
5. If experiencing issues running the program on Windows, select "More Info" at the "Windows Protected Your PC" at the pop-up and then select "Run Away."
6. If experiencing issues running the program on Mac, check out [this link](#) to open packages from unidentified developers.
7. Ensure that any desired EnergyPlus simulations have been run with the following command in the IDF file: "Output:SQLite, SimpleAndTabular"
8. Click the "Load Files button", or drag a valid SQL file (or multiple SQL files) over the load files button.
9. Start exploring your model results!

LIST OF INFLUENTIAL

List of Influential Variables

- How do we consider the values in the model?
- How do we make sure the model is accurate?

List of Influential Variables

System Inputs

1. Systems Variables

- Required power and associated part load curves (e.g., Supply fan, pumps, motors, boiler)
- Efficiency of the systems (e.g., fans, pumps, COP of HVAC systems)
- Maximum supply air flow rate
- Minimum outside air flow rate
- HVAC system types
- Size of the HVAC equipment (Hard sizing vs. autosizing)
- Pressure rise
- Garage fans
- Electric Vehicle (EV) stations
- Exterior lights
- Outdoor air fraction

List of Influential Variables

Internal Inputs

2. Internal Loads

- Lighting power density
- Equipment power density
- Process/Miscellaneous power density
- Occupancy density
- Metabolic activity of occupants and clothing
- Service Hot Water (SHW)

3. Internal Load Schedules

- Lighting schedule
- Equipment schedule
- Process/Miscellaneous schedule
- Occupancy schedule and associated occupancy behavior

List of Influential Variables

Internal Inputs

4. Systems Schedules

- Interior fans schedule
- Space heating and cooling temperature setpoints and setbacks
- Days of operation
- Outside fresh air schedule
- Economizer
- Mechanical outdoor air controller schedule

List of Influential Variables

External Inputs

5. Building Geometry

- GFA (Gross Floor Area) and building Conditioned Floor Area (CFA)
- Building space types
- Number of floors
- Age of the building and equipment (contribute to other variables)
- Building surface to volume ratio
- Building leakage area (contribute to the infiltration)

List of Influential Variables

External Inputs

6. Real Time Weather File

- Dry bulb temperature
- Relative humidity
- Dew point temperature
- Wind speed/direction
- Atmospheric pressure
- Diffuse/direct normal radiation
- Snow and liquid precipitation depth

List of Influential Variables

External Inputs

7. Thermal Characteristics of Building Envelope

- Window shading coefficient (SGHC)
- Window U-value
- Wall U-value
- Floor U-value
- Wall to Window Ratio (WWR)
- Infiltration throughout the building envelope
- Roof type (conventional roof, green roof, and other roofing solutions)

List of Influential Variables

External Inputs

8. Urban Environment Influence

- Local outdoor Convective Heat Transfer Coefficients (CHTCs)
- Urban environment density (e.g., urban plan area density and frontal urban density)
- Land coverage (e.g., vegetated surfaces vs. ground)
- Local outdoor solar irradiance distribution due to the urban environment density

CALIBRATION

Calibration

- Building energy modeling approaches typically require hours or days of intensive data gathering and tuning the building energy model, a process known as ***calibration***.
- Calibration is the process of (i) validate and (2) verify the “*results of a building energy model with the metered energy data*”.
- The calibration process is critical for:
 - Establishing quality control of modeling
 - Creating reliable energy modeling results
 - Designing and retrofitting buildings

Calibration

- ASHRAE Guideline 14-2014 has two calibration metrics:
 1. Coefficient of variation of the root mean square error (CVRMSE)
 2. Normalized Mean Biased Error (NMBE)
- CVRMSE shows how well the model match some months much better than others
- NMBE indicates how well the model tend to over or underestimate actual use?

Calibration

$$CVRMSE = 100 * \frac{1}{\bar{y}} [\sum (y_i - \hat{y}_i)^2 / (n - p)]^{1/2}$$

$$NMBE = \frac{\sum^n (y_i - \hat{y}_i)}{(n - p) * \bar{y}} * 100$$

n = number of data periods (at least 12 months → n=12)

p = number of parameters in baseline model (p=1)

y_i = meter energy data for period i

\bar{y} = mean of meter energy data

\hat{y}_i = simulation-predicted energy data for period i

Calibration

- Calibration requirements:

Statistic	Monthly	Hourly
CV(RMSE)	15%	30%
NMBE	5%	10%

Calibration

- If possible, we would like to calibrate for all end-uses, similar to the following case study:

	CVRSME	NMBE	Months
All Electricity	6.1%	-0.6%	All
Plug Loads	5.9%	-2.1%	All
Lighting	4.9%	2.6%	All
Fans	9.3%	-1.2%	Omit December
Cooling	12.6%	3.6%	Omit December
All Gas	12.0%	2.3%	Omit December
Heating	12.6%	1.7%	Omit December
Service Hot Water	9.5%	2.3%	Omit April and May

CLASS ACTIVITY

Class Activity

- Calculate the CVRMSE and NMBE for your HW3 model:

<https://docs.google.com/spreadsheets/d/1eUYbP00uv7EYI3cB5poRmNHMOfJb292LX-gPelbX1Yo/edit#gid=0>

SENSITIVITY ANALYSIS

Sensitivity Analysis

1. One-factor-at-a-time (+/- 20%, +/- 1 standard deviation):
 - ❑ It only considers the local variation and no interaction between parameters (Why this is an issue?)
 - ❑ Using standard deviation is preferred but requires assuming a distribution (e.g., boiler efficiency 0.88 +/- 20% can give an efficiency of 1.06!)

Sensitivity Analysis

2. Partial Derivatives

$$\textit{sensitivity} = \frac{\partial Y}{\partial X_i} = \frac{\Delta Y}{\Delta X_i}$$

For each parameter X_i , $i = 1, \dots, n$

Sensitivity Analysis

3. Sensitivity Index (Hoffman & Gardener 1983):

$$\text{sensitivity} = \frac{Y_{\max} - Y_{\min}}{Y_{\max}}$$

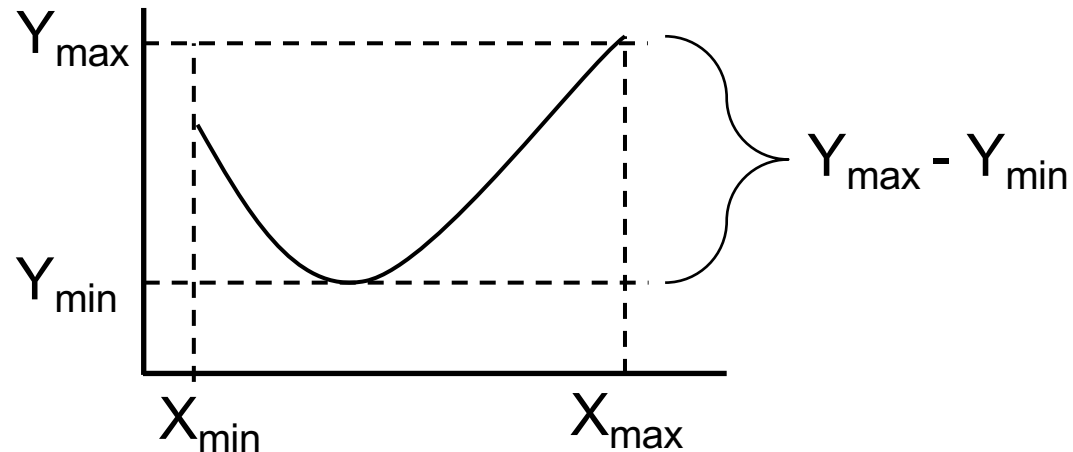

OPENSTUDIO UTILITY

OpenStudio Utility

- We will use the OpenStudio Utility Bills at some point:

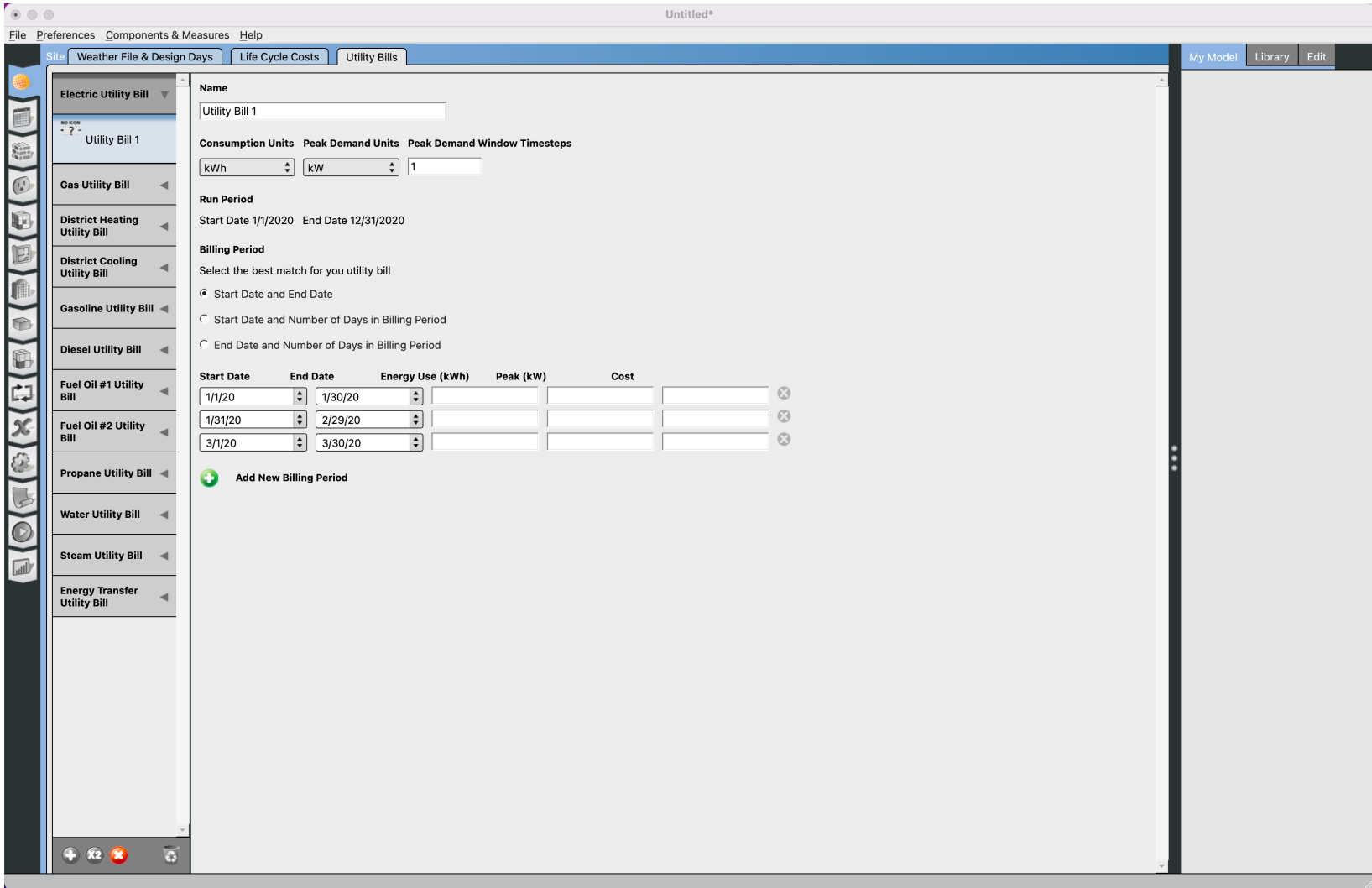

FAN CURVES

Fan Performance

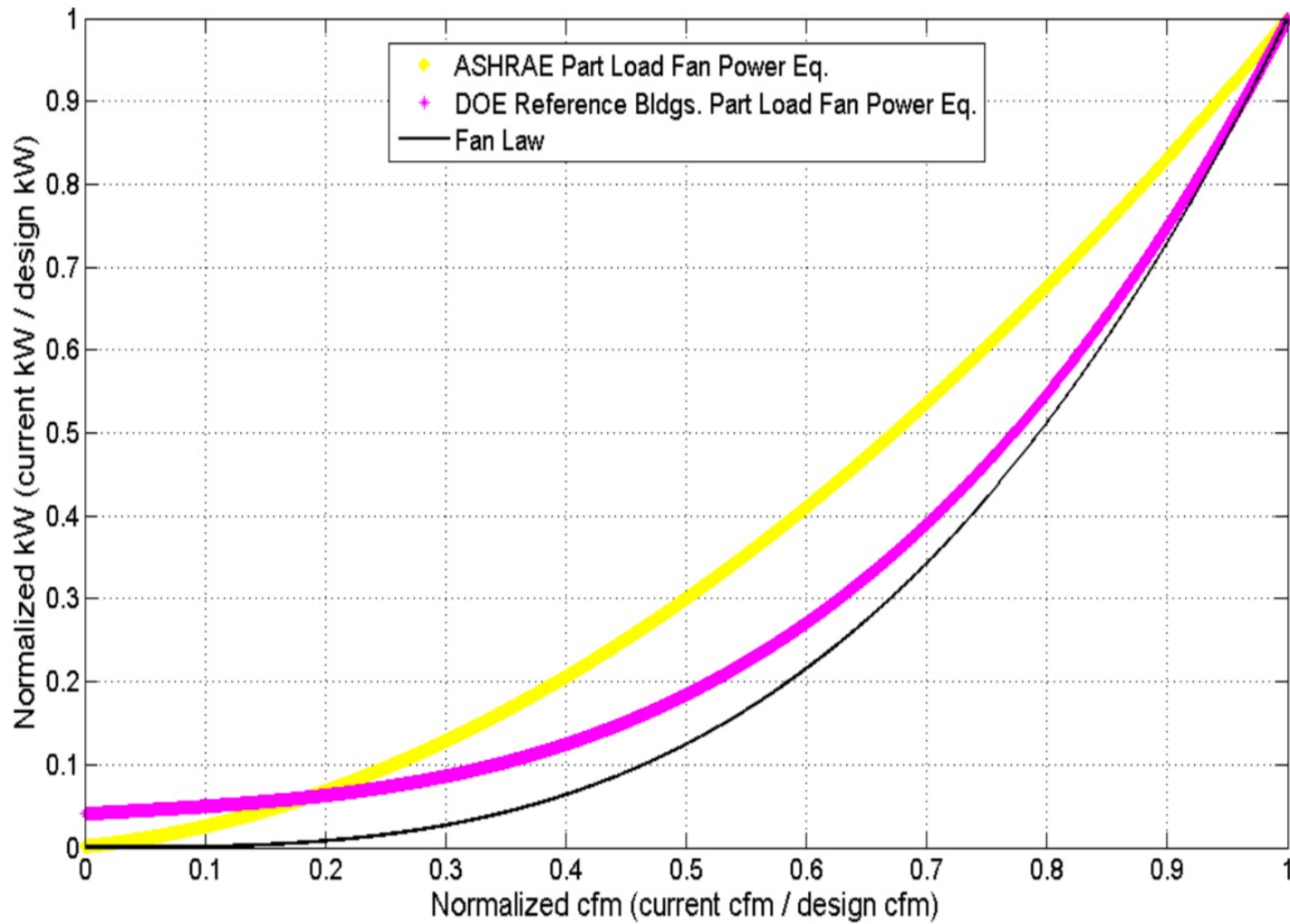

$$P_{fan} = 0.0013 + 0.1470 X + 0.9506 X^2 - 0.0998 X^3$$

Fan Performance

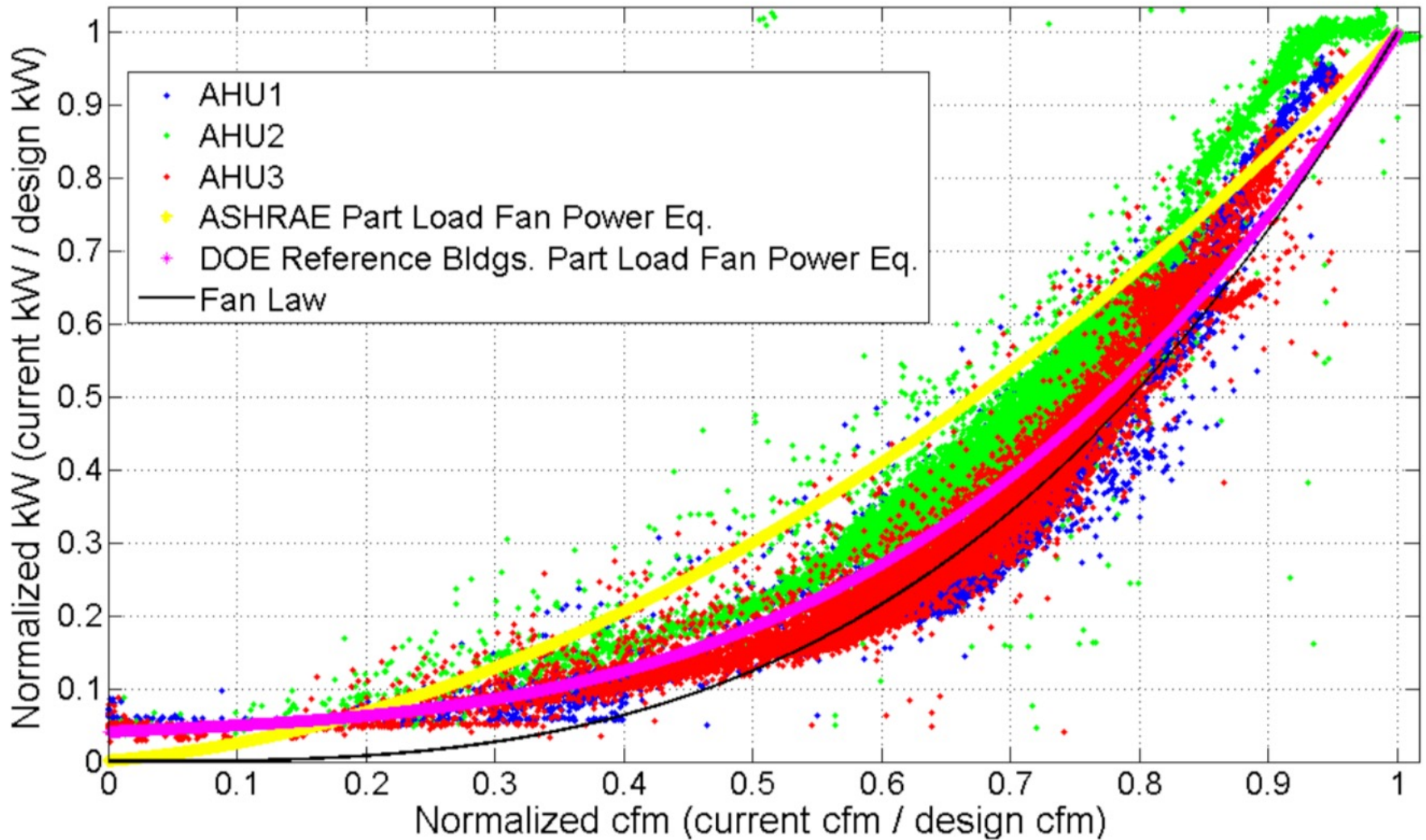

Fan Performance

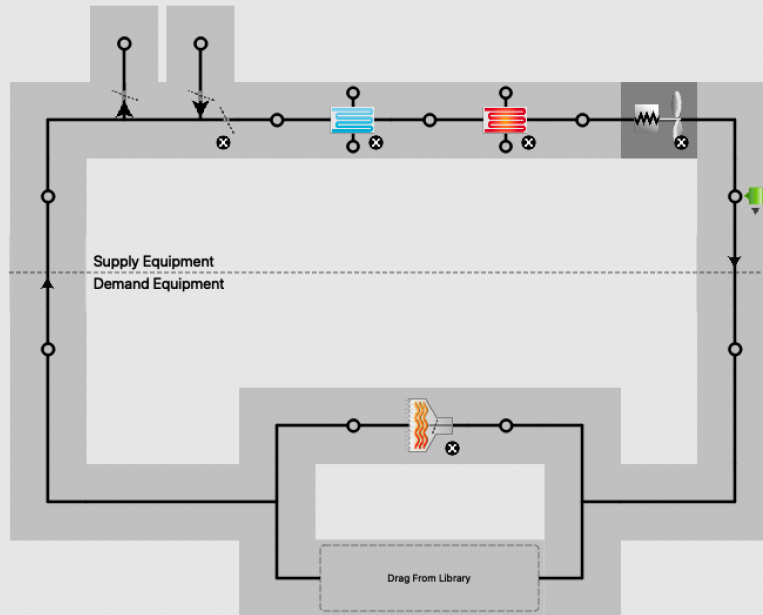

Fan Power Minimum Flow Rate Input Method	FixedFlowRate
Fan Power Minimum Flow Fraction	0
Fan Power Minimum Air Flow Rate	0 cfm
Motor Efficiency	0.9300000000000005
Motor In Airstream Fraction	1
Fan Power Coefficient 1	0.040759893999999998
Fan Power Coefficient 2	0.08804497
Fan Power Coefficient 3	-0.07292611999999997
Fan Power Coefficient 4	0.94373982300000003
Fan Power Coefficient 5	0
End-Use Subcategory	General

Fan Performance

Variable Speed Fan Model

The model for the variable speed fan is similar to the simple single-speed fan model except for a part load factor that multiplies the fan power consumption.

$$f_{flow} = \dot{m} / \dot{m}_{design}$$
$$f_{pl} = c_1 + c_2 \cdot f_{flow} + c_3 \cdot f_{flow}^2 + c_4 \cdot f_{flow}^3 + c_5 \cdot f_{flow}^4$$
$$\dot{Q}_{tot} = f_{pl} \dot{m}_{design} \Delta P / (e_{tot} \rho_{air})$$

The rest of the calculation is the same as for the simple fan.

Nomenclature for Simple Models

\dot{Q}_{tot} is the fan power in watts;

\dot{m} is the air mass flow in kg/s;

\dot{m}_{design} is the design (maximum) air flow in kg/s;

ΔP is the fan design pressure increase in Pascals;

e_{tot} is the fan total efficiency;

ρ_{air} is the air density at standard conditions in kg/m³;

e_{motor} is the motor efficiency;

\dot{Q}_{shaft} is the fan shaft power in watts;

\dot{Q}_{toair} is the power entering the air in watts;

N_{ratio} is the ratio of actual fan flow rate (or speed) to maximum fan flow rate (or speed)

h_{in}, h_{out} are the inlet and outlet air stream specific enthalpies in J/kg;

w_{in}, w_{out} are the inlet and outlet air stream humidity ratios;

T_{out} is the outlet air temperature in degrees C;

AUTOSIZE

Autosize

- EnergyPlus allows sizing the HVAC components based on the loads

The screenshot displays the EnergyPlus software interface. On the left, a schematic diagram of a plant loop is shown, featuring a boiler, pumps, and piping. A red dashed box highlights a specific boiler component in the diagram. On the right, the 'OS:Boiler:HotWater' property panel is visible. The 'Fuel Type' dropdown menu is set to 'NaturalGas'. The 'Nominal Capacity' section shows the 'Autosized' radio button selected, with the 'Autosize' label next to it. The 'Nominal Thermal Efficiency' is set to 0.8. A red dashed box highlights the 'Fuel Type' dropdown and the 'Autosized' radio button.

My Model Library Edit

Plant Loop 1

OS:Boiler:HotWater

Name
Boiler Hot Water 1

Fuel Type
NaturalGas

Nominal Capacity
 Hard Sized W
 Autosized Autosize

Nominal Thermal Efficiency
0.8

Efficiency Curve Temperature

Autosize

- Read EIO file to see the sizing values:

```
eplusout.eio
People Internal Gains Nominal, RTU5_1_LL-PD,COMLAB_OCC_SCH_9-9,RTU5_1_124.95,2.1,55.059,0.441,25.970,0.000,0.648,0.200,0.152,1.000,AutoCalculate,MEDIUM OFFICE ACTIVITY,No,
3.8200E-008,0,20
People Internal Gains Nominal, BB_ONLY_L116 LL-PD,LARGELAB_OCC_SCH,BB_ONLY_L116,225.48,22.4,22.4,2.9,9.929E-002,10.072,0.300,0.700,AutoCalculate,MEDIUM OFFICE
ACTIVITY,No,3.8200E-008,0,22
People Internal Gains Nominal, BB_ONLY_L119 LL-PD,LARGELAB_OCC_SCH,BB_ONLY_L119,146.04,14.5,14.5,9.929E-002,10.072,0.300,0.700,AutoCalculate,MEDIUM OFFICE
ACTIVITY,No,3.8200E-008,0,14
People Internal Gains Nominal, BB_ONLY_L123 LL-PD,LARGELAB_OCC_SCH,BB_ONLY_L123,42.36,4.2,4.2,9.929E-002,10.072,0.300,0.700,AutoCalculate,MEDIUM OFFICE ACTIVITY,No,
3.8200E-008,0,4
People Internal Gains Nominal, BB_ONLY_L221 LL-PD,LARGELAB_OCC_SCH,BB_ONLY_L221,53.51,5.3,5.3,9.929E-002,10.072,0.300,0.700,AutoCalculate,MEDIUM OFFICE ACTIVITY,No,
3.8200E-008,0,5
People Internal Gains Nominal, PTAC_L119A LL-PD,LARGELAB_OCC_SCH,PTAC_L119A,21.18,2.1,2.1,9.929E-002,10.072,0.300,0.700,AutoCalculate,MEDIUM OFFICE ACTIVITY,No,
3.8200E-008,0,2
People Internal Gains Nominal, PTAC_L120 LL-PD,LARGELAB_OCC_SCH,PTAC_L120,85.84,8.5,8.5,9.929E-002,10.072,0.300,0.700,AutoCalculate,MEDIUM OFFICE ACTIVITY,No,
3.8200E-008,0,9
! <Lights Internal Gains Nominal>,Name,Schedule Name,Zone Name,Zone Floor Area {m2},# Zone Occupants,Lighting Level {W},Lights/Floor Area {W/m2},Lights per person {W/
person},Fraction Return Air,Fraction Radiant,Fraction Short Wave,Convected,Fraction Replaceable,End-Use Category,Nominal Minimum Lighting Level {W},Nominal
Maximum Lighting Level {W}
Lights Internal Gains Nominal, C.O_C1_3,OFFICE_LIGHT_SCH_9-8,RTU1_1,124.95,2.1,55.059,0.441,25.970,0.000,0.648,0.200,0.152,1.000,General,0.000,55.059
Lights Internal Gains Nominal, C.O_C1_5,OFFICE_LIGHT_SCH_9-8,RTU1_1,124.95,2.1,55.059,0.441,25.970,0.000,0.648,0.200,0.152,1.000,General,0.000,55.059
Lights Internal Gains Nominal, C.O_C1_7,OFFICE_LIGHT_SCH_9-8,RTU1_1,124.95,2.1,80.470,0.644,37.956,0.000,0.648,0.200,0.152,1.000,General,0.000,80.470
Lights Internal Gains Nominal, C.O_C2_3,OFFICE_LIGHT_SCH_9-8,RTU1_1,124.95,2.1,100.000,0.800,47.168,0.000,0.648,0.200,0.152,1.000,General,0.000,100.000
Lights Internal Gains Nominal, COR-C1_6,BLDG_LIGHT_24_HR,RTU1_1,124.95,2.1,120.000,0.960,56.601,0.000,0.648,0.200,0.152,1.000,General,120.000,120.000
Lights Internal Gains Nominal, C.O_R2_2,OFFICE_LIGHT_SCH_9-8,RTU2_1,101.45,2.7,81.000,0.798,30.264,0.000,0.333,0.200,0.467,1.000,General,0.000,81.000
Lights Internal Gains Nominal, C.O_R3_3,OFFICE_LIGHT_SCH_9-8,RTU2_1,101.45,2.7,162.000,1.597,60.527,0.000,0.333,0.200,0.467,1.000,General,0.000,162.000
Lights Internal Gains Nominal, C.O_R_3,OFFICE_LIGHT_SCH_9-8,RTU2_1,101.45,2.7,54.000,0.532,20.176,0.000,0.333,0.200,0.467,1.000,General,0.000,54.000
Lights Internal Gains Nominal, C.O_R2_1,OFFICE_LIGHT_SCH_9-8,RTU5_1,409.61,9.7,84.375,0.206,8.676,0.000,0.333,0.200,0.467,1.000,General,0.000,84.375
Lights Internal Gains Nominal, C.O_R3_1,OFFICE_LIGHT_SCH_9-8,RTU5_1,409.61,9.7,175.781,0.429,18.075,0.000,0.333,0.200,0.467,1.000,General,0.000,175.781
Lights Internal Gains Nominal, C.O_R3_2,OFFICE_LIGHT_SCH_9-8,RTU5_1,409.61,9.7,260.156,0.635,26.750,0.000,0.333,0.200,0.467,1.000,General,0.000,260.156
Lights Internal Gains Nominal, C.O_R_2,OFFICE_LIGHT_SCH_9-8,RTU5_1,409.61,9.7,48.316,0.118,4.968,0.000,0.333,0.200,0.467,1.000,General,0.000,48.316
Lights Internal Gains Nominal, COR-R1_2,BLDG_LIGHT_24_HR,RTU5_1,409.61,9.7,106.176,0.259,10.918,0.000,0.333,0.200,0.467,1.000,General,106.176,106.176
Lights Internal Gains Nominal, LIGHTS_10,L117_LGT_SCH_9-5,RTU5_1,409.61,9.7,515.061,1.257,52.961,0.000,0.648,0.200,0.152,1.000,General,0.000,515.061
Lights Internal Gains Nominal, LIGHTS_9,L117_LGT_SCH_9-5,RTU5_1,409.61,9.7,432.824,1.057,44.505,0.000,0.648,0.200,0.152,1.000,General,0.000,432.824
Lights Internal Gains Nominal, LIGHTS_11,BLDG_LIGHT_24_HR,UNCON_BASE,598.67,0.0,299.250,0.503,N/A,0.000,0.648,0.200,0.152,1.000,General,299.250,299.250
Lights Internal Gains Nominal, LIGHTS_12,BLDG_LIGHT_24_HR,UNCON_BASE,598.67,0.0,65.835,0.110,N/A,0.000,0.648,0.200,0.152,1.000,General,65.835,65.835
Lights Internal Gains Nominal, LIGHTS_13,BLDG_LIGHT_24_HR,UNCON_BASE,598.67,0.0,212.625,0.355,N/A,0.000,0.648,0.200,0.152,1.000,General,212.625,212.625
Lights Internal Gains Nominal, LIGHTS_14,BLDG_LIGHT_24_HR,UNCON_BASE,598.67,0.0,88.515,0.148,N/A,0.000,0.648,0.200,0.152,1.000,General,88.515,88.515
Lights Internal Gains Nominal, LIGHTS_15,BLDG_LIGHT_24_HR,UNCON_BASE,598.67,0.0,17.640,2.947E-002,N/A,0.000,0.648,0.200,0.152,1.000,General,17.640,17.640
Lights Internal Gains Nominal, LIGHTS_16,BLDG_LIGHT_24_HR,UNCON_BASE,598.67,0.0,325.080,0.543,N/A,0.000,0.648,0.200,0.152,1.000,General,325.080,325.080
Lights Internal Gains Nominal, LIGHTS_17,BLDG_LIGHT_24_HR,UNCON_BASE,598.67,0.0,428.400,0.716,N/A,0.000,0.648,0.200,0.152,1.000,General,428.400,428.400
Lights Internal Gains Nominal, LIGHTS_18,BLDG_LIGHT_24_HR,UNCON_BASE,598.67,0.0,133.875,0.224,N/A,0.000,0.648,0.200,0.152,1.000,General,133.875,133.875
```

Autosize

- Look for the “HVAC System Sizing”:

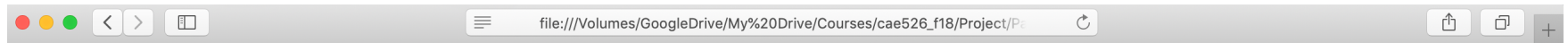

Table of Contents

- [Top](#)
- [Annual Building Utility Performance Summary](#)
- [Input Verification and Results Summary](#)
- [Demand End Use Components Summary](#)
- [Source Energy End Use Components Summary](#)
- [Component Sizing Summary](#)
- [Surface Shadowing Summary](#)
- [Adaptive Comfort Summary](#)
- [Initialization Summary](#)
- [Climatic Data Summary](#)
- [Envelope Summary](#)
- [Shading Summary](#)
- [Lighting Summary](#)
- [Equipment Summary](#)
- [HVAC Sizing Summary](#)
- [Coil Sizing Details](#)
- [System Summary](#)
- [Outdoor Air Summary](#)
- [Object Count Summary](#)
- [Energy Meters](#)
- [Sensible Heat Gain Summary](#)
- [Standard 62.1 Summary](#)
- [LEED Summary](#)

Autosize

- What are the pro and cons of using the autosizing feature?

CLASS ACTIVITY

Class Activity

- Find six or seven autosize values and replace them in the model.
- Create a new model “save as” and increase or decreases the sizes and comment on the results

<https://docs.google.com/spreadsheets/d/1eUYbP00uv7EYl3cB5poRmNHMOFJb292LX-gPelbX1Yo/edit#gid=1275549135>

SETPOINTS

Setpoints

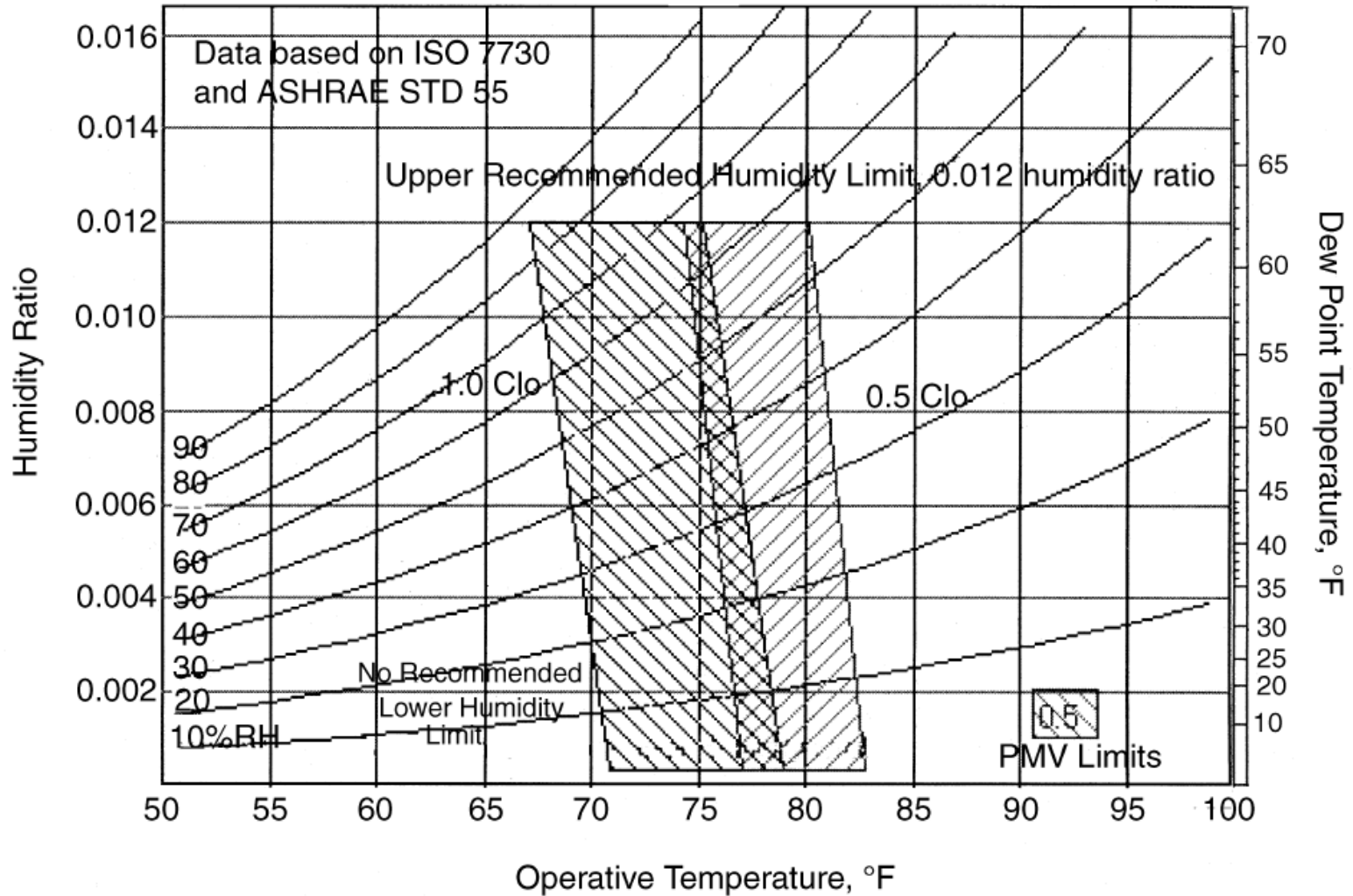

Setpoints

- Poor management of temperature setpoints in the buildings

Thermal comfort range

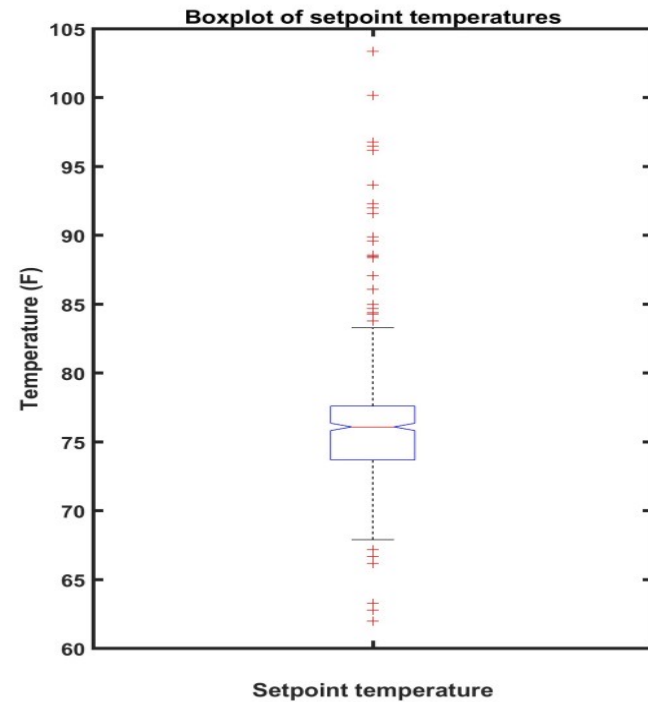
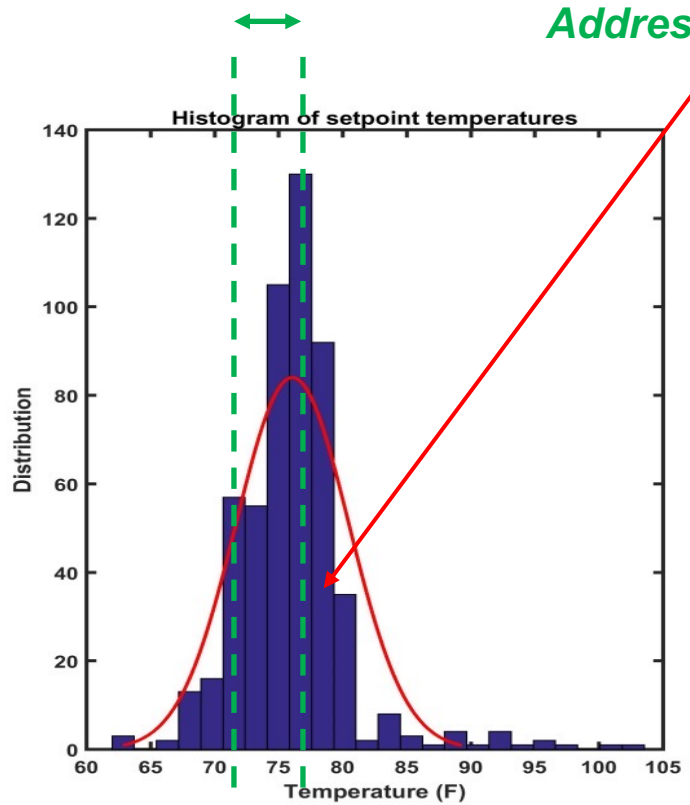

Setpoints

- Wishnick Hall monthly data:

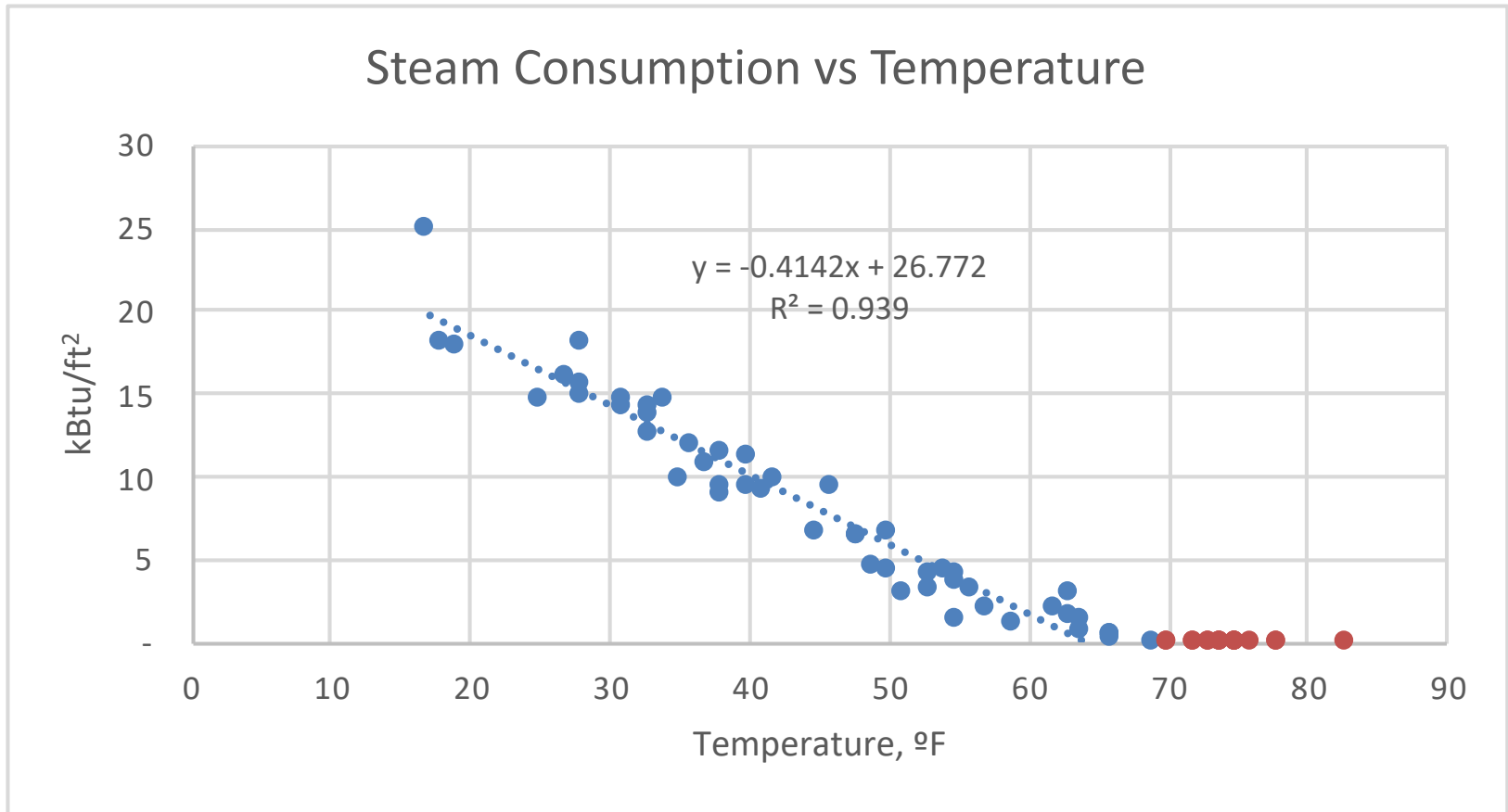

Setpoints

- Wishnick Hall monthly data:

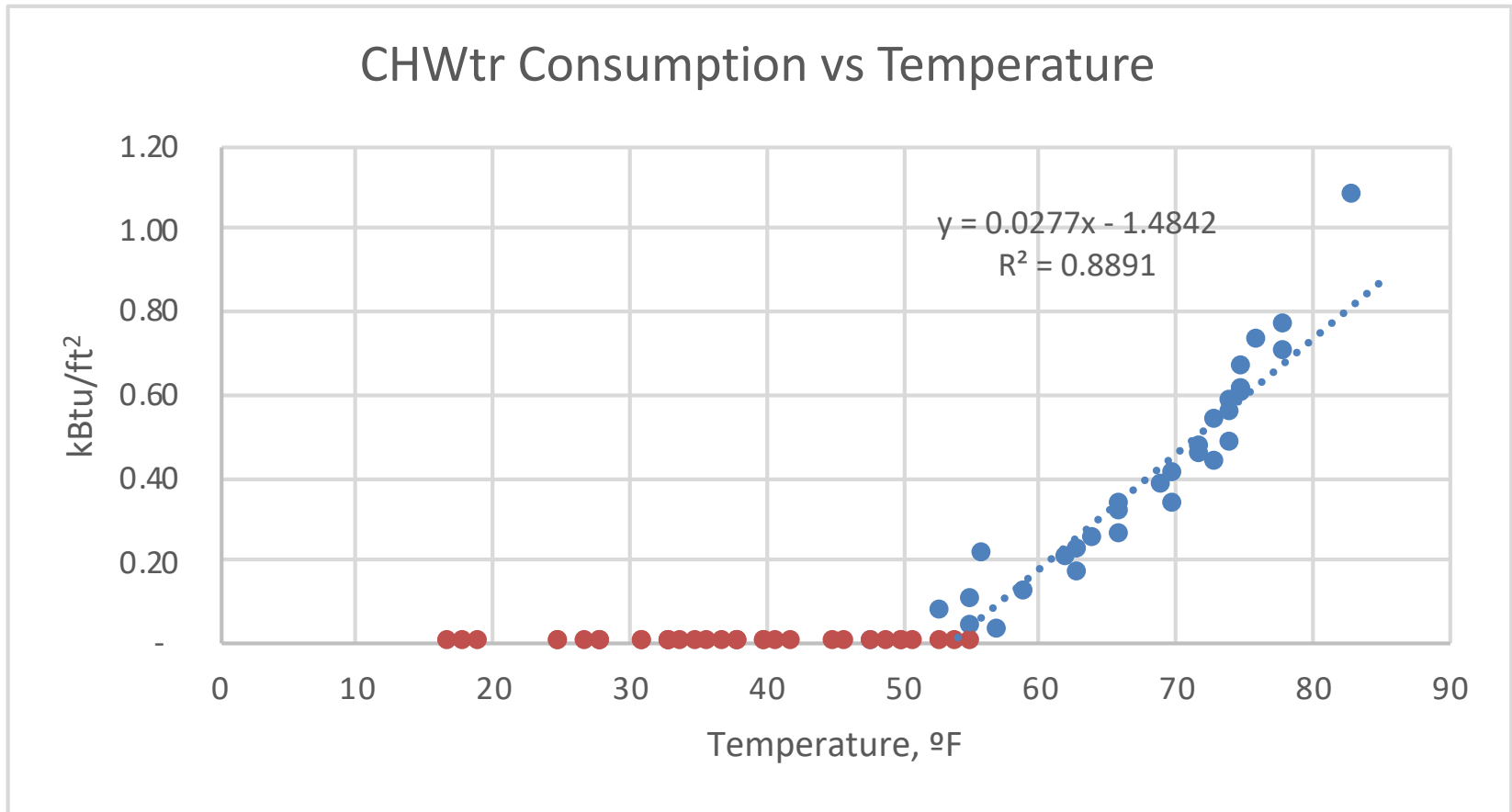

OCCUPANCY

Occupancy

- Occupancy and utility data as a proxy to obtain receptacles and schedules

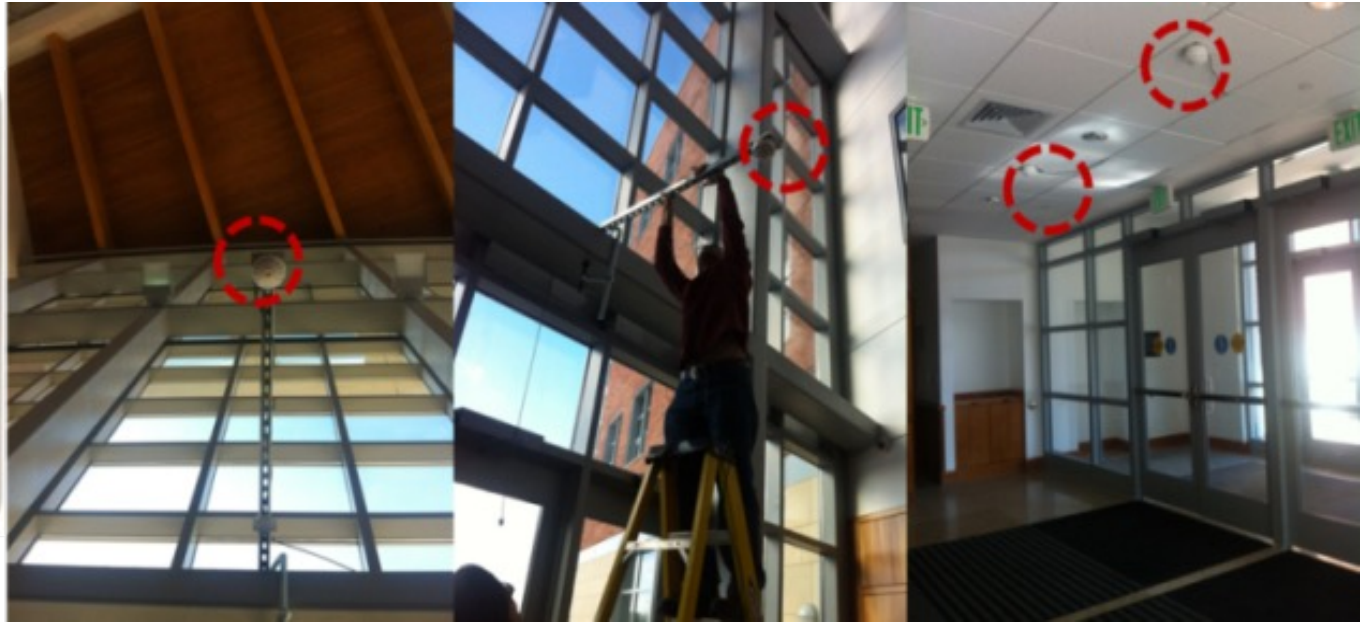

Occupancy

- Careful consideration for the campus buildings is associated with modeling occupancy rate of the buildings:
 - Combination of different space types, rendering the campus buildings unique in terms of the occupancy rate
 - Does not follow the typical occupancy rates recommended in the energy simulation programs

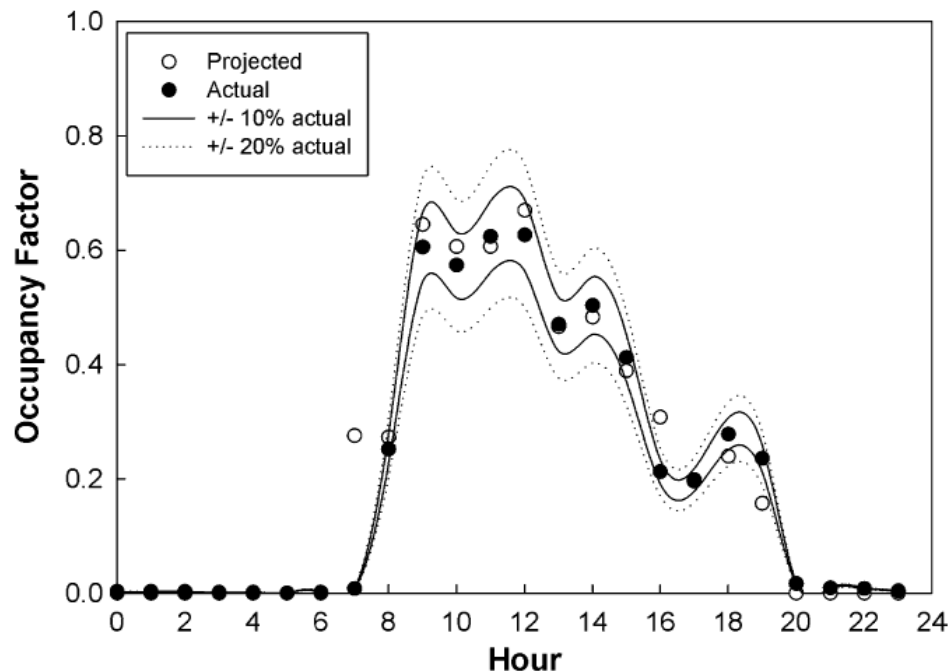

Class Activity

- We can use different strategies including using the course schedules:

← → ↻ Not Secure | pop.weclarify.com/spring2019.html ☆ 3d | M

Search for Options

BIOL 327: Introduction to Immunology

[View in course catalog](#) / [View course evaluations](#) (must login to MyIIT first)

Covers general principles of innate and adaptive immunity including structure and function of immune system components, T and B cell development, responses of the immune system to infection, and consequences of immune system failure.

Eligible Pass/Fail Course, Standard Tuition Rate

Spring 2019 | 4 seats avail. | [Lecture \(Class\) ~ Karina Tuz ~ TR from 11:25am to 12:40pm in Stuart Building 204 \(add to cart\)](#)

Ready to register? **Check if these sections are full**

- **BIOL 327: Introduction to Immunology**
Class ~ Karina Tuz ~ in Stuart Building 204 (remove)
- **BIOL 402: Metabolic Biochemistry**
Class ~ Nicholas Menhart ~ in Stuart Building 107 (remove)
Internet ~ Nicholas Menhart ~ in TBA (remove)
- **BIOL 410: Medical Microbiology**
Class ~ Kathryn Spink ~ in Stuart Building 213 (remove)
Class ~ Kathryn Spink ~ in TBA (remove)
- **BIOL 451: Biological Literature**
Class ~ Andrew Howard ~ in Stuart Building 212 (remove)
- **BIOL 510: Medical Microbiology**
Class ~ Kathryn Spink ~ in Stuart Building 213 (remove)

BIOL 402: Metabolic Biochemistry

[View in course catalog](#) / [View course evaluations](#) (must login to MyIIT first)

The second part of a one-year Biochemistry series. This semester deals with biochemistry of metabolism, focusing on: glycolysis, the citric acid cycle, gluconeogenesis, electron transport, and the synthesis and breakdown of biomolecules (amino acids, nucleic acids, lipids, and carbohydrates), blood chemistry, lipid transportation, and metabolic control.

Eligible Pass/Fail Course, Standard Tuition Rate

Spring 2019 | [15 seats avail. | Lecture \(Class\) ~ Nicholas Menhart ~ TR from 1:50pm to 3:05pm in Stuart Building 107 \(add to cart\)](#)
[9 seats avail. | Lecture \(Internet\) ~ Nicholas Menhart \(add to cart\)](#)

Spring 2019 (101)

8am	Sunday	Monday	Tuesday	Wednesday	Thursday	Friday	Saturday
9am							CSP 586
10am						CS 331	
11am						CS 330	
12pm							
1pm							
2pm						BIOL 451	
3pm						GLS 180	
4pm							
5pm						CS 201	
6pm						CS 587	
7pm							
8pm							
9pm							

BIOL 410: Medical Microbiology

[View in course catalog](#) / [View course evaluations](#) (must login to MyIIT first)

Properties of pathogenic bacteria, fungi, viruses, and parasites and their mechanisms of pathogenesis with a focus on organisms that cause human disease.

Eligible Pass/Fail Course, Standard Tuition Rate

Spring 2019 | [3 seats avail. | Lecture \(Class\) ~ Kathryn Spink ~ TR from 10am to 11:15am in Stuart Building 213 \(add to cart\)](#)
[7 seats avail. | Lecture \(Class\) ~ Kathryn Spink \(add to cart\)](#)

BIOL 451: Biological Literature

[View in course catalog](#) / [View course evaluations](#) (must login to MyIIT first)

Library research on advanced topics in biology followed by oral presentations of this research.

Occupancy

- Beyond installation of fairly expensive occupancy sensors at the entrance and exit of buildings is to benefit from the existing infrastructures at the buildings:
 - Appliance using WiFi or desktop computers connect to the network through their IP address
 - Swipe access card readers for a building or space
 - Class schedules and FTE operation hours
 - CO₂ sensors for the demand control systems

Occupancy

- From the Penn State's campus study:

Fall semester

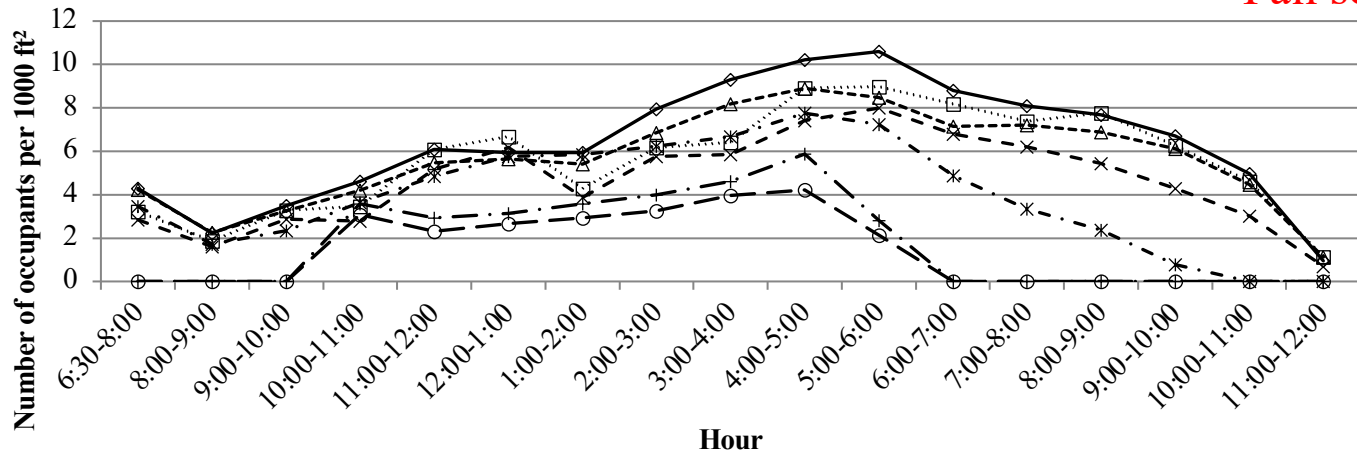

—◇— Monday ···□··· Tuesday - -△- - Wednesday - × - Thursday - * · Friday —○— Saturday —+— Sunday

Spring semester

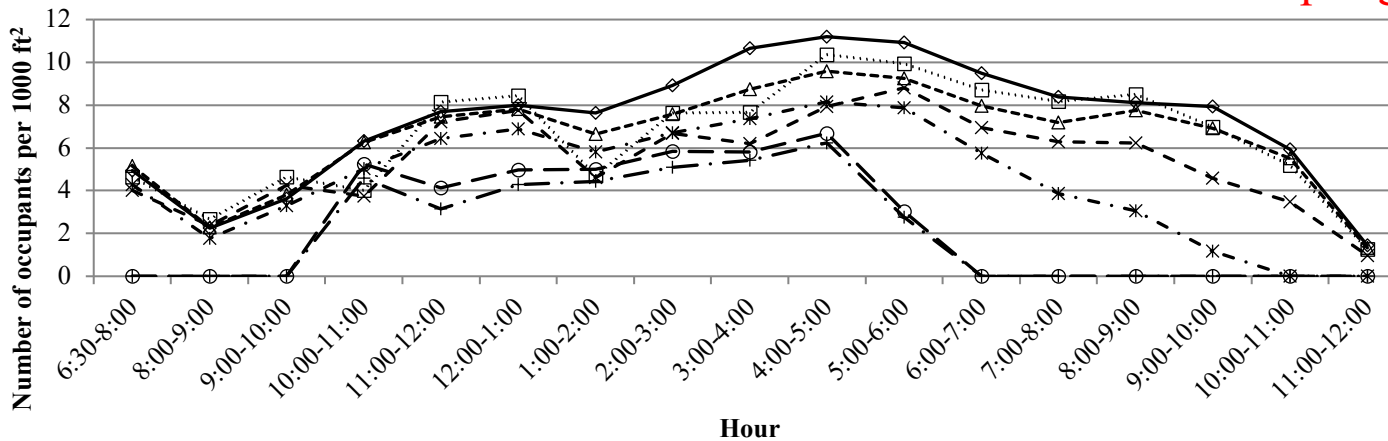

—◇— Monday ···□··· Tuesday - -△- - Wednesday - × - Thursday - * · Friday —○— Saturday —+— Sunday

DESIGN VENTILATION

Outdoor Air

- Minimum outdoor air fraction very important
- EnergyPlus options:
 - OA per person (default 20 cfm)
 - OA per floor area
 - OA per zone
 - OA air change per hour
 - Use $\sim 0.1-0.2$ CFM/ft² (or 20% design flow rate)
 - Look at floor plans & ASHRAE 62.1

INFILTRATION

Infiltration

- Infiltration options in E+:
 - Design Flow Rate:

$$\text{Infiltration} = (I_{Design})(F_{Schedule})[A + B[T_{Zone} - T_{Out}] + C(\text{Wind Speed}) + D(\text{Wind Speed})]$$

- Effective Leakage Area:

$$\text{Infiltration} = (F_{Schedule}) \frac{A_L}{1000} \sqrt{C_S \Delta T + C_W (\text{Wind Speed})^2}$$

- Flow Coefficient

$$\text{Infiltration} = (F_{Schedule}) \sqrt{(cC_S \Delta T^n)^2 + (cC_W (s \times \text{Wind Speed})^{2n})^2}$$

PLUG LOAD

Plug Load Schedule

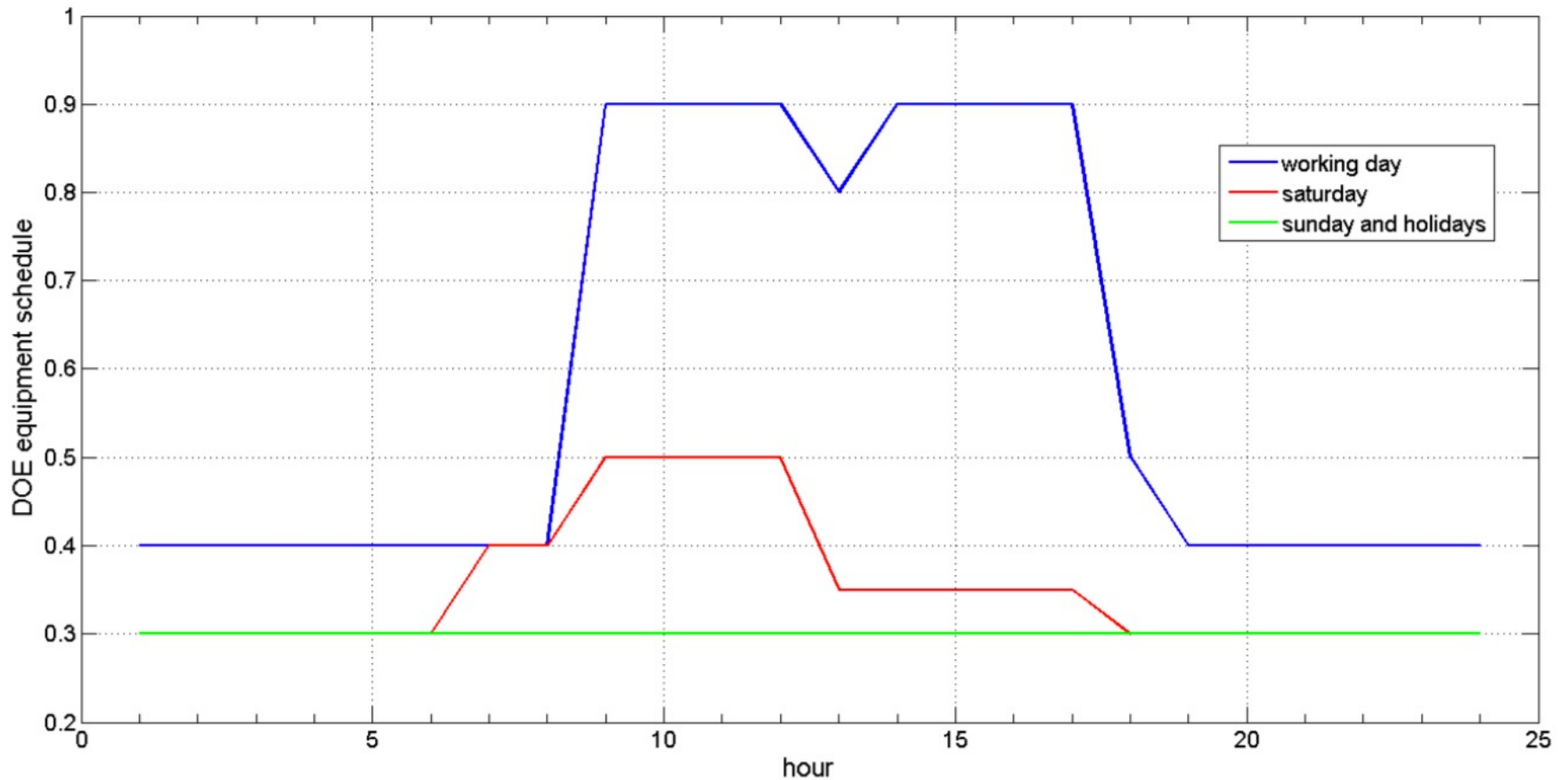

Is this close to the reality?

Plug Load Schedule

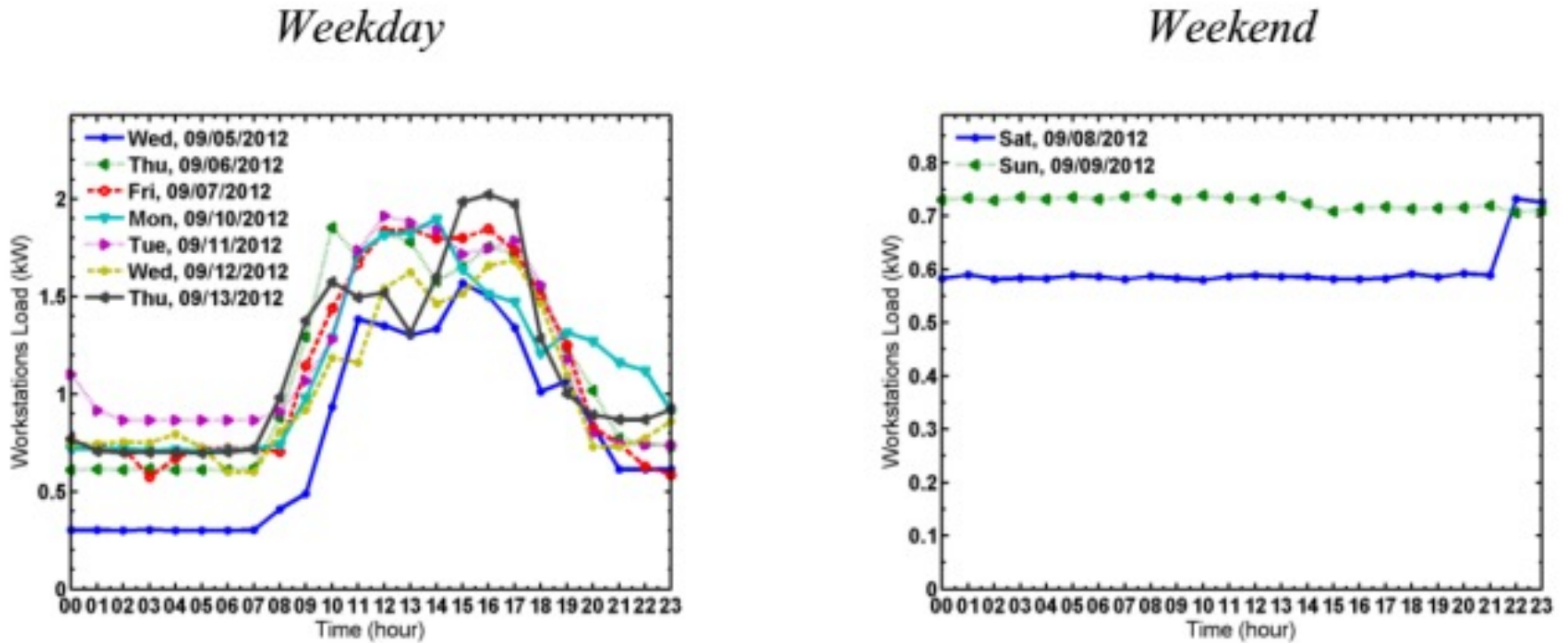

Figure 4. Plug load profiles for workstations.

LIGHTING

Lighting Load



$$f_{\text{convected}} = 1.0 - (\text{Fraction Latent} + \text{Fraction Radiant} + \text{Fraction Lost})$$

Lighting Schedule

- Suggested DOE Reference building lighting schedule

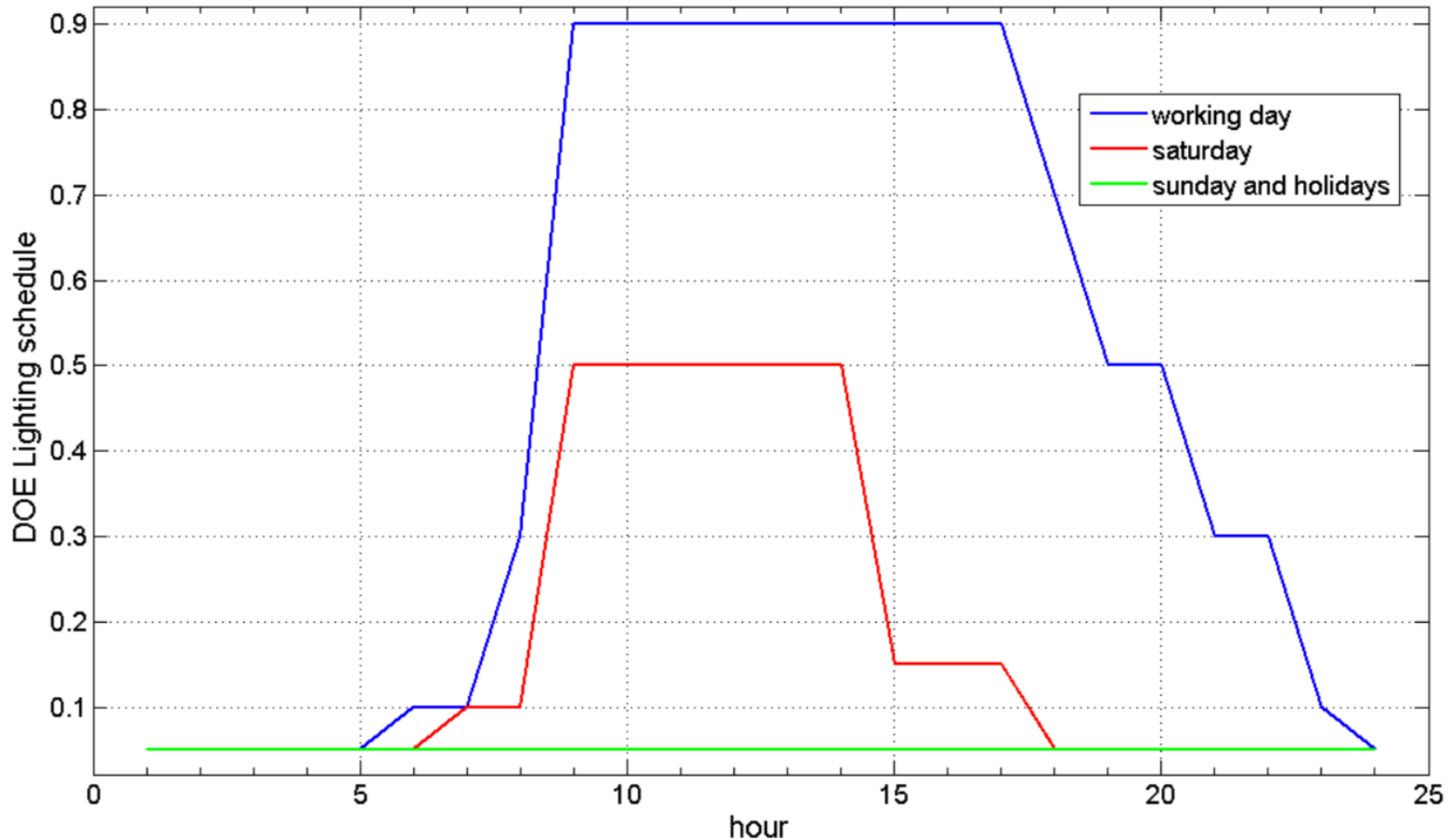

Is this close to the reality?

Lighting Power Density

- Lighting Power Density (LPD)

**TABLE 9.5.1 Lighting Power Densities
Using the Building Area Method**

Building Area Type ^a	LPD (W/ft ²)
Automotive facility	0.82
Convention center	1.08
Courthouse	1.05
Dining: bar lounge/leisure	0.99
Dining: cafeteria/fast food	0.90
Dining: family	0.89
Dormitory	0.61
Exercise center	0.88
Fire station	0.71
Gymnasium	1.00
Health-care clinic	0.87
Hospital	1.21
Hotel	1.00
Library	1.18
Manufacturing facility	1.11
Motel	0.88
Motion picture theater	0.83
Multifamily	0.60
Museum	1.06
Office	0.90
Parking garage	0.25
Penitentiary	0.97
Performing arts theater	1.39
Police station	0.96
Post office	0.87
Religious building	1.05
Retail	1.40
School/university	0.99
Sports arena	0.78
Town hall	0.92
Transportation	0.77
Warehouse	0.66
Workshop	1.20

^a In cases where both a general building area type and a specific building area type are listed, the specific building area type shall apply.

Is this close to the reality?

Lighting Power Use

- Lighting power use is equal to =

$$\textit{Diversity Factor} \times \textit{LPD} \times \textit{Area}$$

CLASS ACTIVITY

Class Activity

- Calculate the LPD, occupancy, plug load, and associated schedules for this room:

<https://docs.google.com/spreadsheets/d/1eUYbP00uv7EYI3cB5poRmNHMOFJb292LX-gPelbX1Yo/edit#gid=1480758816>

SIMULATION

Convergence Tolerances

- Convergence tolerances during warm up days:
 - ❑ Design days or run periods repeat until the simulation reaches to the desired convergence tolerances
 - ❑ There will be a warning is the convergence is not met during the load calculations
 - ❑ It is possible to increase the number of warm up days

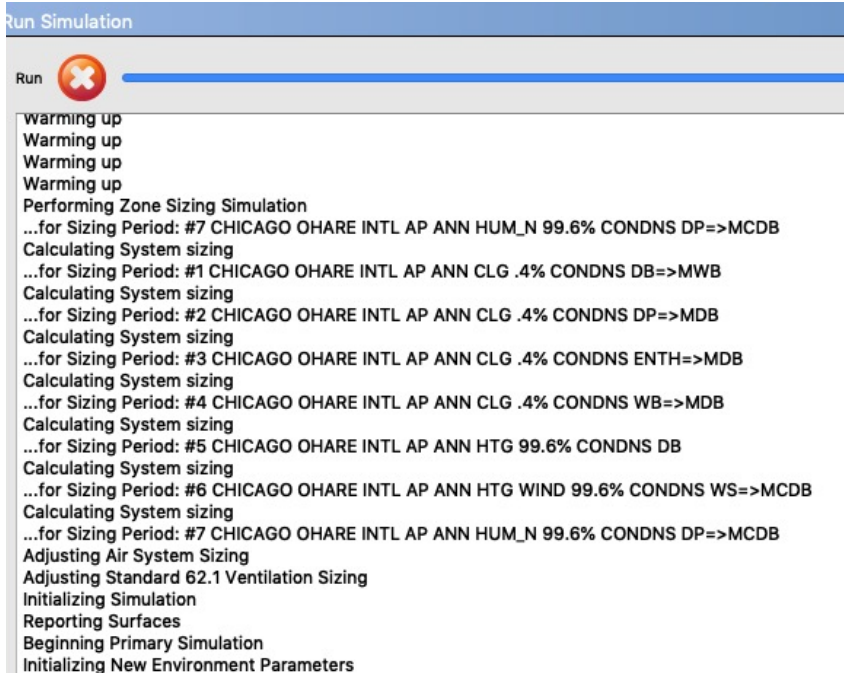

```
Run Simulation
Run
warming up
Warming up
Warming up
Warming up
Performing Zone Sizing Simulation
...for Sizing Period: #7 CHICAGO OHARE INTL AP ANN HUM_N 99.6% CONDNS DP=>MCDB
Calculating System sizing
...for Sizing Period: #1 CHICAGO OHARE INTL AP ANN CLG .4% CONDNS DB=>MWB
Calculating System sizing
...for Sizing Period: #2 CHICAGO OHARE INTL AP ANN CLG .4% CONDNS DP=>MDB
Calculating System sizing
...for Sizing Period: #3 CHICAGO OHARE INTL AP ANN CLG .4% CONDNS ENTH=>MDB
Calculating System sizing
...for Sizing Period: #4 CHICAGO OHARE INTL AP ANN CLG .4% CONDNS WB=>MDB
Calculating System sizing
...for Sizing Period: #5 CHICAGO OHARE INTL AP ANN HTG 99.6% CONDNS DB
Calculating System sizing
...for Sizing Period: #6 CHICAGO OHARE INTL AP ANN HTG WIND 99.6% CONDNS WS=>MCDB
Calculating System sizing
...for Sizing Period: #7 CHICAGO OHARE INTL AP ANN HUM_N 99.6% CONDNS DP=>MCDB
Adjusting Air System Sizing
Adjusting Standard 62.1 Ventilation Sizing
Initializing Simulation
Reporting Surfaces
Beginning Primary Simulation
Initializing New Environment Parameters
```

CALIBRATION EXAMPLES

Calibration Example 1

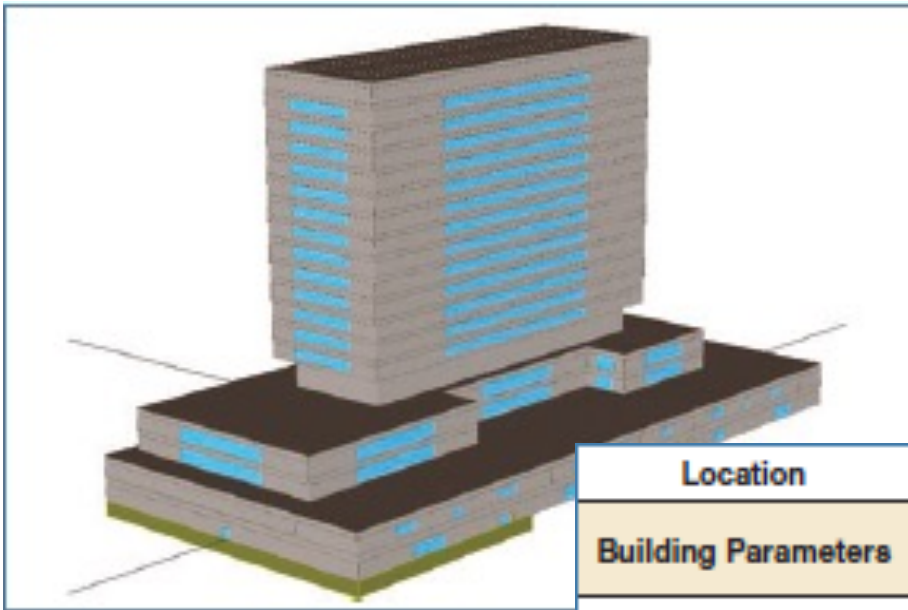

Location	Baltimore, ASHRAE Climate Zone 4A
Building Parameters	735,300 ft ² Includes 17 Above-Grade Stories and a 1.5 Story Below-Grade Parking Garage; Late 1960s Construction
Space Use	Mainly Office Space for Government Agencies
Occupancy	1,200 People
HVAC System	Multiple VAV AHUs on Lower Three Levels, Two-Pipe FCUs at the Perimeter Zones in the Upper Levels, Dedicated Outside Air AHUs Provide Ventilation to the Entire Building
Lighting System	Mainly 4 ft T8 lamps with Electronic Ballasts
Chilled Water Source	Purchased at About \$0.30/ton-hr (2009) (Disabled On-Site Chilled Water Plant)
Hot Water Source	Purchased Steam at About \$21.50/thousand lbs (2009)
Cost of Electricity	\$0.121/kWh Blended Rate (2009)

Calibration Example 1

- Calculate the lighting power:



30
PACK

Philips Model 479733 Internet #303811988 Store SO SKU #1001078187

32-Watt 4 ft. Cool White Linear T8 Fluorescent Light Bulb (30-Pack)

~~NOT YET RATED~~

Includes 30 bulbs (\$1.79 /bulb)

[Compare to Discontinued Model](#)

↑ ↓ ↻

View

- Calculate people density

Calibration Example 1

Known Values	Source	Approach
HVAC Equipment Capacities, Efficiencies	As-Built Drawings, Verified On Site	Acceptable level of accuracy achieved with collected information. These values were fixed during model calibration.
HVAC Operating Schedules	BAS, Conversations with Staff	
HW, CHW, AHU Setpoints	BAS, Conversations with Staff	
Fan and Pump Peak kW	Calculated From amp Readings and Nameplates	
HVAC Functional Conditions	BAS, On-Site Functional Testing	
Lighting Power Densities	As-Built Drawings, Verified On Site	
Lighting Controls	Conversations with Staff, Verified On Site	
Building Geometry	Construction Documents, Verified On Site	
Window Geometry and Performance	Cut Sheets, Verified On Site	
Cost of CHW, Steam, and Electricity	Contracts with Utilities and Utility Bills	
Roughly Known Values	Source	Approach
Ventilation Airflow Rates	BAS (Damper Positions) and MEP Schedules	Fixed Based on Best Estimate
Wall and Roof R-Values	As-Built Drawings, Unverified	Fixed (Minor Impact on Results)
Data Center Airflow Rates	CRAC Equipment Capacities, Site Observations	Fixed Based on Best Estimate
Elevator Energy Use	Typical Values From Published Research	Fixed (Minor Energy Use)
Weather	TMY2 File for Baltimore	See Sensitivity Analysis (Table 5)
Unknown Values	Source for Range	Approach
Plug Load Power and Schedules	Experience, Occupant Density, and Publications	Used for Electricity Calibration
Kitchen Energy Use	Typical Values and Conversations with Staff	Fixed (Minor Energy Use)
Building Infiltration	Typical Values for Similar Buildings	Used for CHW Calibration
Parking Garage Infiltration	Typical Values and Observations	Used as a Single Variable for Steam Calibration
Steam Valve Leakage	Estimated Based on Observations	

Calibration Example 1

		Annual Error	Monthly Normalized Mean Biased Error	Coefficient of Variation Of the Root Mean Squared Error
	ASHRAE Guideline 14	–	±5%	15%
	NREL Requirements	±10%	–	–
Calibrated Model	Electricity	–1%	–1%	4%
	Steam	0%	0%	33%
	Chilled Water	–12%	–13%	13%
	Energy Costs	–5%	–5%	12%

Calibration Example 2

Table 1. Common Adjustments Made During Hand-Calibration to Monthly Utility Data

Measure Name	Description and Comments	Importance
Adjust Infiltration	Adjust per-area infiltration. Adjust infiltration or outside air, not both. Use default unless building seems extra-leaky.	Primary
Adjust Outside Air	Adjust the mechanical ventilation provided to a space. Usually listed correctly on newer buildings' drawings, but often uncertain in older buildings, or affected by damper faults.	Primary
Occupancy Sensor Savings	Adjust the savings associated with occupancy sensors in a certain space. Inspection of actual operation may justify a deviation from the ASHRAE default credit of 10%.	Secondary
Heating and Cooling Temperature Set Points	Adjust the thermal zone air temperature set point for the heating or cooling system. As an easily adjustable operational variable, this may be uncertain.	Secondary
Supply Air Temperature	Adjust the supply air temperature, possibly in support of a seasonal reset strategy. Typically these are constant values, but in some cases the BAS shows a range.	Secondary
Chilled and Hot Water Temperature Set Points	Adjust the temperature at which chilled water and hot water are supplied (typically to one or more air systems). These are typically constant, but certain conditions (inaccessible controls, BAS shows a range) may introduce uncertainty.	Secondary
Economizer Set Points	Adjust the economizer set points. May be uncertain if the control system is inaccessible.	Secondary
Fan and Pump	Adjust the fan or pump motor efficiency. This is likely to be	Secondary

Calibration Example 3

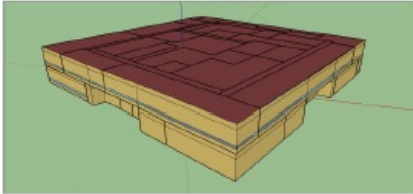

Change	Rationale
Raise site ground temperature from default of 18.0°C (64.4°F) to 19.9°C (67.82°F).	Apply rule of thumb that ground temperature is 2°C (3.6°F) lower than average indoor air temperature.
Increase cooling set point to 24.4°C (76°F)	Occupants report hot spots and modeled energy use was significantly higher than actual.
Adjust lighting and electric equipment schedules.	Simplified the schedule shapes, and brought the overall values in line with rules of thumb based on occupancy, nighttime lighting levels, and plug load types.
Reduce electric equipment loads by 40%	The diversity of plug loads all applied with the same schedule, and the disproportionate share of plug loads as compared to lighting loads.
Hard size fans to 1.00 cfm/ft ² (0.00508 m ³ /s·m ²)	Autosized fan motors were undersized compared to actual, known values. 1 cfm/ft ² is a rule of thumb.
Increase the fan static pressure to 3.5 in. H ₂ O (870 Pa)	The fans motors were still too small after hardsizing to 1 cfm/ft ² .
Reset the supply air temperature to 15.55°C (60°F) (from 12.77°C [55°F]) in winter	After the shoulder and summer season energy use was brought in line, the winter energy use was still too high. The end use breakdown showed considerable cooling plus reheat, and the controls on the chiller were not fully audited, leaving open the possibility of winter reset.

Calibration Example 3

Table 3 Final Parameter Values

PARAMETER	MANUAL CALIBRATION	AUTOMATED CALIBRATION
Ground temperature (°C)	19.9	19.83
Cooling set point (°C)	24.4	26.19
Reduce lighting power (%)	0 ¹	28.25
Reduce equipment power (%)	40	37.98
Fan static pressure (in. H ₂ O)	3.5	2.43
NMBE	-1.35%	0.09%
CV(RMSE)	7.61%	8.43%

Table 1 Parameter Ranges

PARAMETER	INITIAL	MIN	MAX
Ground temperature (°C)	18	17	20
Cooling set point (°C)	22.2	22.2	26.2
Reduce lighting power (%)	0.0	0.0	40.0
Reduce equipment power (%)	0.0	0.0	40.0
Fan static pressure (in. H ₂ O)	2.0	2.0	4.0

Calibration Example 4

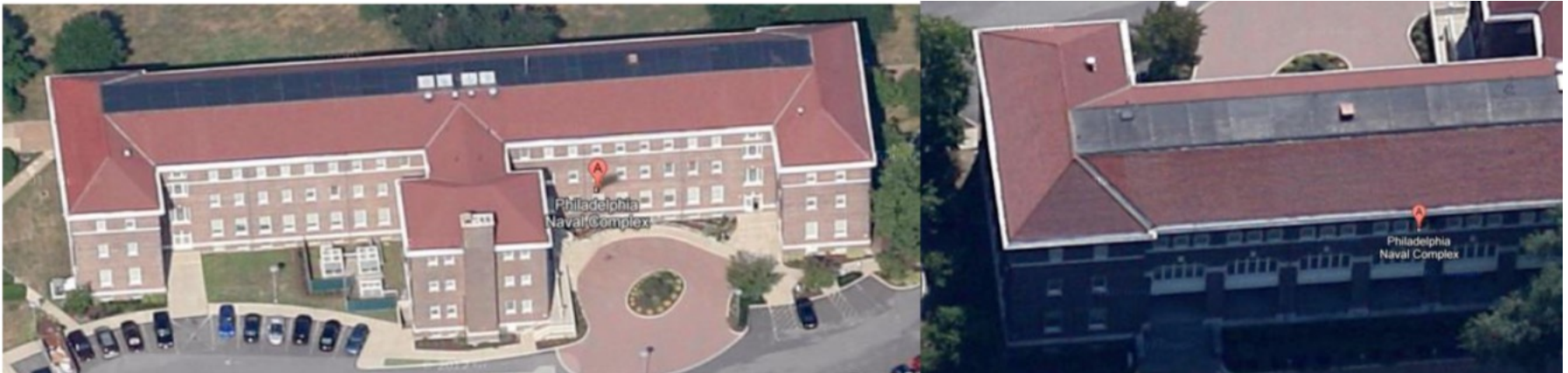

Space Types	Area (ft²)
Office	39,812
Conference	2,632
Lobby	7,038
Bathroom	1,380
Stair	3,800
Unoccupied	8,905
MechRoom	4,500

Calibration Example 4

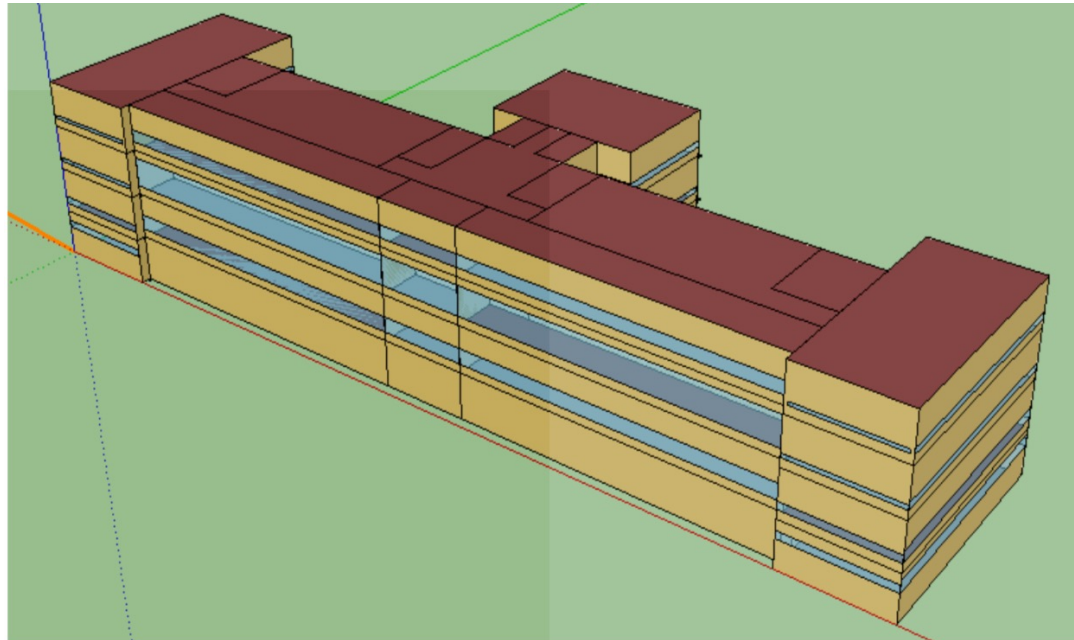
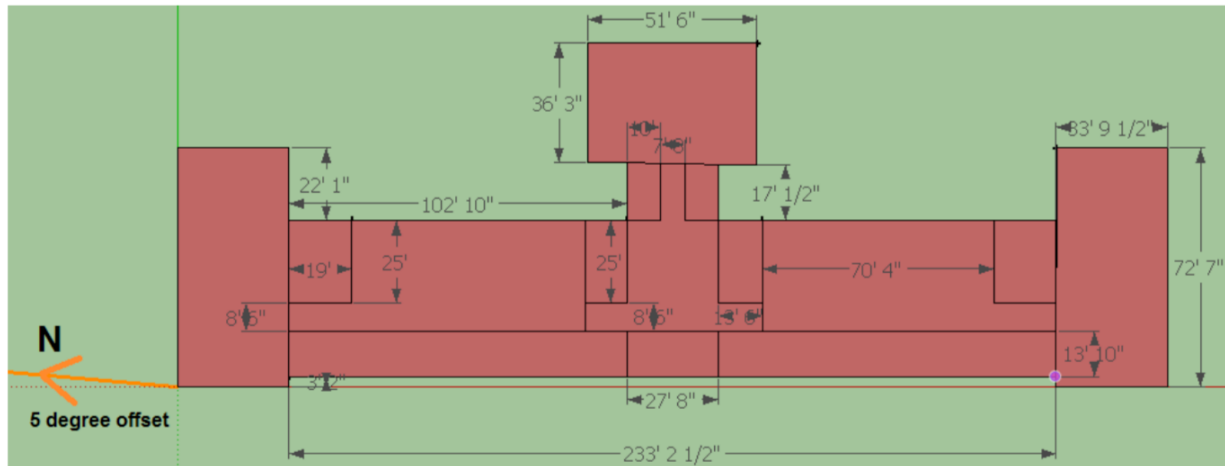

Calibration Example 4

	CVRSME	NMBE	Months
All Electricity	6.12%	-0.60%	all
All Gas	12.0%	2.3%	omit Dec
Heating	12.55%	1.77%	omit Dec
Service Hot Water	9.51%	2.26%	omit Apr, May
Plug Loads	5.92%	-2.11%	all
Lighting	4.87%	2.57%	all
Fans	9.31%	-1.18%	omit Dec
Cooling	12.62%	3.63%	omit Dec

Calibration Example 4

Building Component	Conductivity (Btu/ft-h-F)	Thickness (in)	R-value
Windows			
6mm Clear Glass	0.520	0.236	0.038
13mm Air	0.024	0.512	1.777
6mm Clear Glass	0.520	0.236	0.038
		Total	1.815
SHGC	0.764		
Visible Transmittance	0.812		
Exterior Wall			
Brick	0.333	18.000	4.500
		Total	4.500
Exterior Wall Below Ground			
Cast Concrete	0.346	22.000	5.299
		Total	5.299
Exterior Floor			
Cast Concrete	0.346	18.000	4.335
Wood Flooring	0.580	5.000	0.718
		Total	5.054
Roof			
Clay Roof Tile	0.580	1.000	0.144
Roof Felt	0.690	0.197	0.024
Roof Sheating	0.092	1.000	0.909
Glass Fibre Insulation	0.025	6.000	20.000
		Total	21.076

Calibration Example 4

Window Face	Construction Name	Area (ft ²)	WWR
1st Front	A1, DR1, DR2, DR4	963.7	33%
2nd Front	P1	149.0	64%
3rd Front	C1	803.6	27%
1st FrontSide	A1	68.0	16%
2nd FrontSide	A2	38.3	9%
3rd FrontSide	A2A	36.7	7%
Bsmt FrontSide	D1	26.2	16%
BsmtSide	D1	91.7	25%
1st Side	A1	238.0	25%
2nd Side	A2	134.2	14%
3rd Side	A2A	128.3	12%
1st BackEnd	A2	76.7	12%
2nd BackEnd	E1	53.3	8%
3rd BackEnd	E2	47.8	7%
1st BackSide	A2	76.7	16%
2nd BackSide	E1	53.3	12%
3rd BackSide	A2	76.7	14%

Calibration Example 4

Space Name	Thermal Zone	Space Type (AirFlow)	Area (ft²)	Design CFM
Bsmt_Lobby_Mid	Lobby_Mid	Lobby	1284	0
Bsmt_Lobby_Mid2	Lobby_Mid	Unoccupied	383	0
Bsmt_Lobby_Mid_N	Lobby_Mid	Unoccupied	1421	0
Bsmt_Lobby_Mid_S	Lobby_Mid	Unoccupied	1422	0
Bsmt_LunchRoom_North	Bsmt_North	Lobby	1904	1200
Bsmt_MechRoom	Lobby_Mid	Unoccupied	1867	600
Bsmt_MechRoomAHU2_South	Bsmt_South	Unoccupied	338	100
Bsmt_MechRoom_AHU3_North	Bsmt_North	Unoccupied	321	100
Bsmt_Mens_Mid	Lobby_Mid	Bathroom	173	350
Bsmt_Storage_NorthEnd	Bsmt_North	Unoccupied	2453	600
Bsmt_Office_SouthEnd	Bsmt_South	Office	2450	400
Bsmt_Office_South	Bsmt_South	Office	1881	1860
Bsmt_Stairway_North	Stair_North	Stair	475	0
Bsmt_Stairway_South	Stair_South	Stair	475	0
Bsmt_Womens_Mid	Lobby_Mid	Bathroom	173	350
1st_Lobby_Mid	Lobby_Mid	Lobby	1284	1200
1st_Lobby_Mid2	Lobby_Mid	Unoccupied	383	0

Calibration Example 4

Fan Energy Calibration Divergence, December 2012

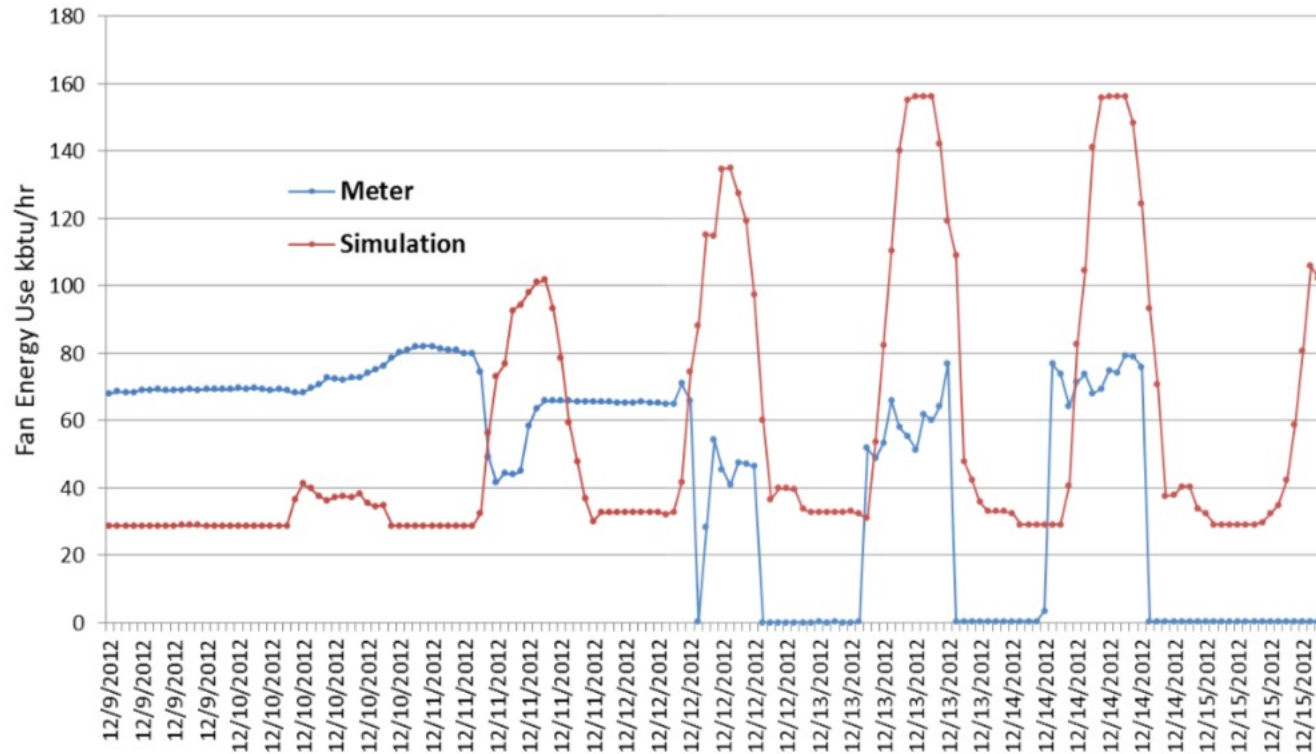

Calibration Example 4

Equipment Power Density			
(Source: Delgoshaei et al., 2013)			
Space Type	EPD		Schedule
Office	1.00	W/ft ²	Equipment Schedule
Intensive Office	2.00	W/ft ²	Equipment Schedule
Conference	1.00	W/ft ²	Equipment Schedule
Lobby	1.00	W/ft ²	Always On
Bathroom	0.00	W/ft ²	N/A
Stair	0.00	W/ft ²	N/A
Unoccupied	0.00	W/ft ²	N/A
Fraction Latent	0	(default)	
Fraction Radiant	0.3	(default)	
Fraction Lost	0	(default)	

Calibration Example 4

Occupancy Schedule		Lighting Schedule		Equipment Schedule	
Weekday	Fraction	Weekday	Fraction	Weekday	Fraction
6:00	0.00	7:00	0.20	8:00	0.60
7:00	0.10	8:00	0.30	10:00	0.80
8:00	0.20	9:00	0.70	17:00	0.90
12:00	0.95	17:00	0.90	18:00	0.70
13:00	0.50	18:00	0.70	24:00	0.60
17:00	0.95	20:00	0.50	Weekend	
18:00	0.70	22:00	0.30	24:00	0.60
20:00	0.40	24:00	0.20		
22:00	0.10	Weekend			

Building Energy Modeling

Lighting Power Density

(Source: Lighting Drawings)

Space Type	LPD	Schedule
Office	1.15 W/ft ²	Lighting Schedule
Intensive Office	1.15 W/ft ²	Lighting Schedule
Conference	2.32 W/ft ²	Lighting Schedule
Lobby	1.25 W/ft ²	Always On
Bathroom	1.15 W/ft ²	Lighting Schedule
Stair	0.59 W/ft ²	Always On
Unoccupied	0.47 W/ft ²	Always Off
Fraction Radiant	0.4 (default)	
Fraction Visible	0.2 (default)	
Return Air Fraction	0 (default)	

Calibration Example 4

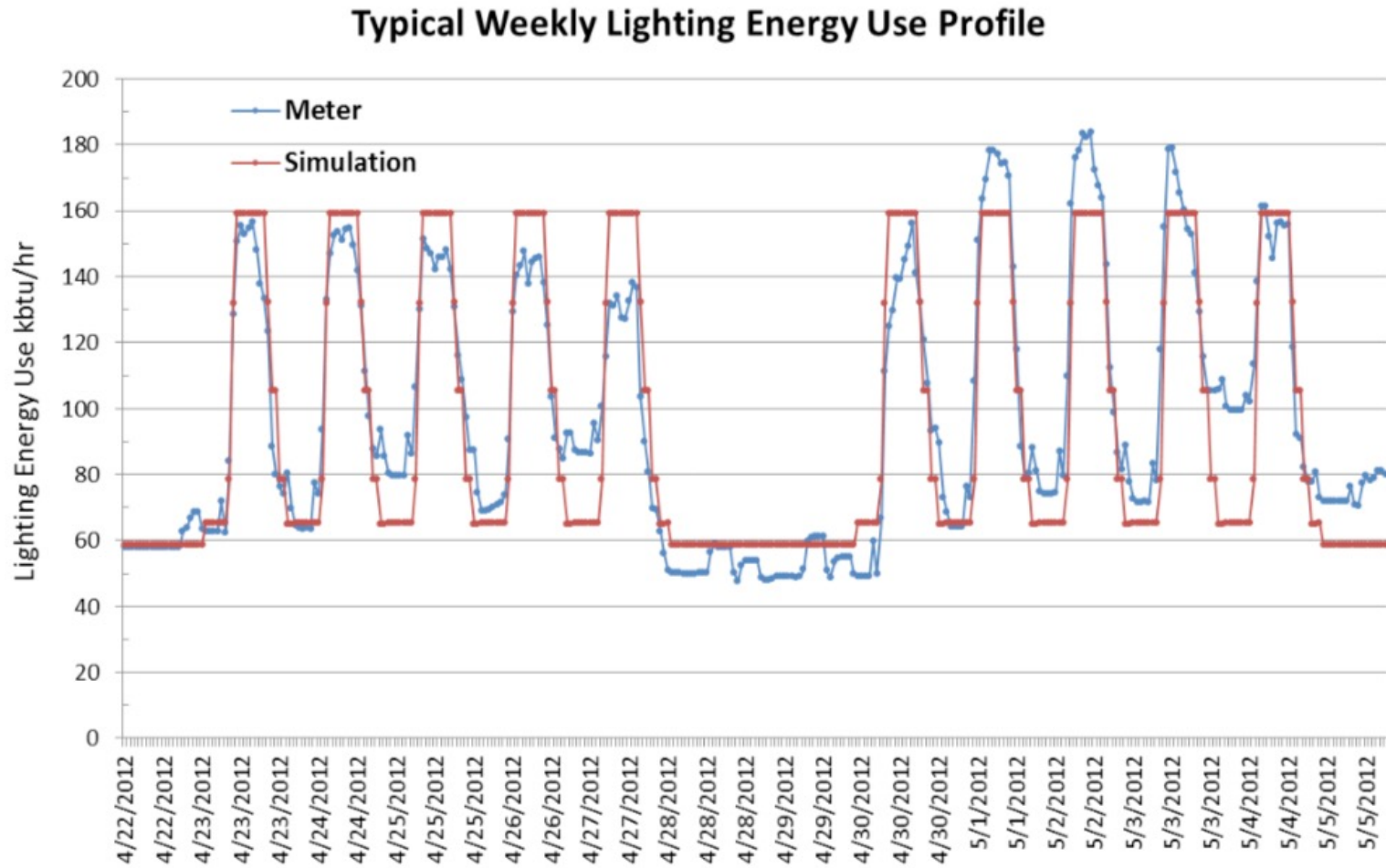

Calibration Example 4

Boiler	Value	Units	Source
Boiler Input	2049000	btu/hr	nameplate
Boiler Nominal Capacity	1632000	btu/hr	nameplate
Nominal Thermal Efficiency	0.796		nameplate
Design Water Outlet	180	°F	drawings
Design Water Flow Rate	84	gpm	calculated

Calibration Example 4

Fan Variable Volume	AHU1	AHU2	AHU3	Source
Fan Efficiency	0.668	0.69	0.689	AHU Details
Pressure Rise (inH ₂ O)	4.50	4.88	4.33	AHU Details
Maximum Flow Rate (cfm)	13639	24575	24823	AHU Details
Motor Efficiency	0.93	0.93	0.93	AHU Details
Design Flow Rate (cfm)	11340	21400	20500	AHU Details
Air Loop				
Maximum Outdoor Air Flow Rate (cfm)	13639	24575	24823	AHU Details
Minimum Outdoor Air Flow Rate (cfm)	1850	2300	2300	AHU Details
Design Outdoor Air Flow Rate (cfm)	1850	2300	2300	AHU Details
Minimum System Air Flow Ratio	0.293	0.350	0.346	AHU Details
Heating Coil				
Maximum Water Flow Rate (gpm)	5.0	5.4	5.4	AHU Details
Rated Capacity (btu/hr)	150107	205088	203861	AHU Details
Rated Inlet Water Temperature (°F)	180.0	180.0	180.0	AHU Details
Rated Inlet Air Temperature (°F)	42.0	53.0	53.0	AHU Details
Rated Outlet Water Temperature (°F)	120.0	104.0	104.5	AHU Details
Rated Outlet Air Temperature (°F)	53.8	62.0	62.3	AHU Details
Controller Convergence Tolerance ®	0.0018	0.0018	0.0018	simulation
Maximum Actuated Flow (cfm)	0.6674	0.7204	0.7204	simulation

Calibration Example 4

Heating Setpoint Schedule			Cooling Setpoint Schedule		
01/01-04/05	71	°F	01/01-03/11	71.5	°F
04/06-04/19	50	°F	03/12-05/17	73	°F
04/20-04/29	71	°F	05/18-06/21	71	°F
04/30-05/17	72.5	°F	06/22-07/24	72.5	°F
05/18-09/26	68	°F	07/25-09/26	70.5	°F
09/27-11/04	71.75	°F	09/27-11/04	72	°F
11/05-12/04	71.25	°F	11/05-12/31	71.5	°F
12/05-12/31	68	°F			