

CAE 208 / MMAE 320: Thermodynamics

Fall 2023

October 26, 2023

Mass & energy analysis of control volumes (4)

Built
Environment
Research

@ IIT



*Advancing energy, environmental, and
sustainability research within the built environment*

www.built-envi.com

Dr. Mohammad Heidarinejad, Ph.D., P.E.
Civil, Architectural and Environmental Engineering
Illinois Institute of Technology

muh182@iit.edu

ANNOUNCEMENTS

Announcements

- Assignment 6 is due tonight
- Assignment 7 is posted

RECAP

Recap

- Total energy of a flowing fluid is:

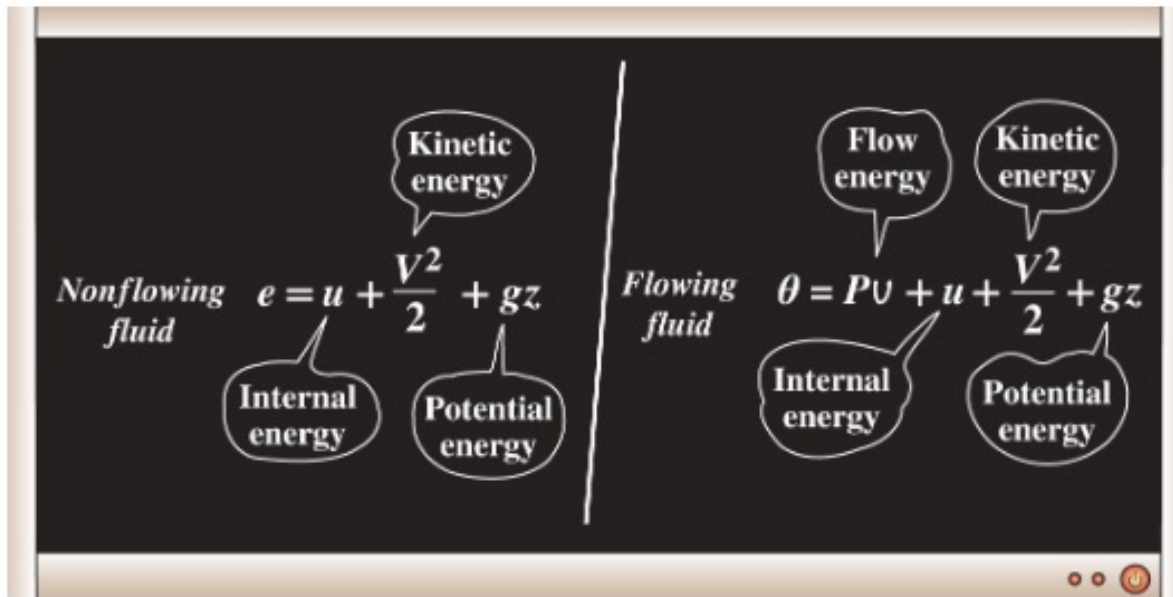

$$\theta = Pv + e = Pv + (u + ke + pe) = (u + Pv) + ke + pe$$

Recap

- Steady-flow process:
 - ❑ No intensive or extensive properties within the control volume change with time
 - ❑ Boundary work is zero
 - ❑ $\Delta E_{CV} = 0$

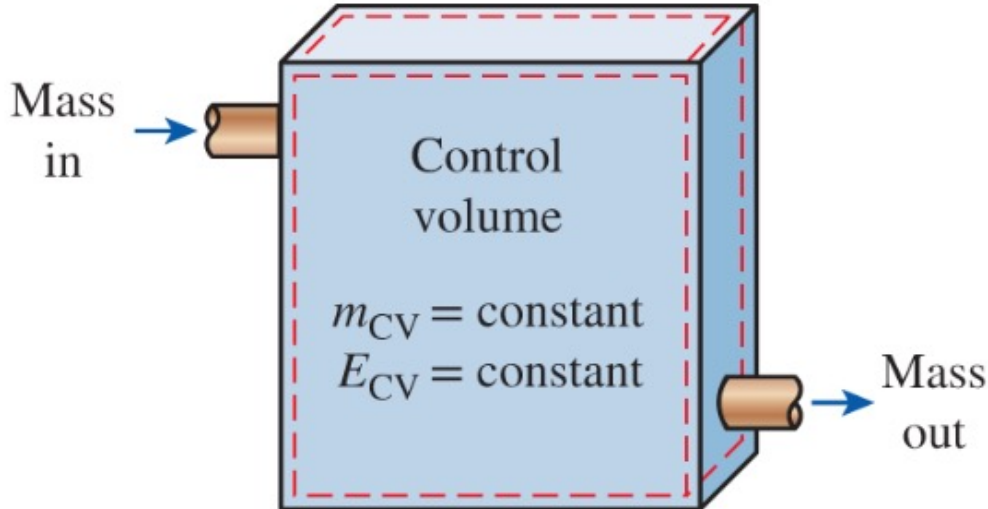

Recap

- Steady-flow process:

$$\sum_{in} \dot{m} = \sum_{out} \dot{m}$$

Recap

- Steady-flow process:

$$\dot{E}_{in} - \dot{E}_{out} = \frac{dE_{system}}{dt} = 0 \qquad \dot{E}_{in} = \dot{E}_{out}$$

$$\dot{Q}_{in} + \dot{W}_{in} + \sum_{in} \dot{m}\theta = \dot{Q}_{out} + \dot{W}_{out} + \sum_{out} \dot{m}\theta$$

$$\dot{Q}_{in} + \dot{W}_{in} + \sum_{in} \dot{m}\left(h + \frac{V^2}{2} + gz\right) = \dot{Q}_{out} + \dot{W}_{out} + \sum_{out} \dot{m}\left(h + \frac{V^2}{2} + gz\right)$$

Recap

- **Nozzles and Diffusers**

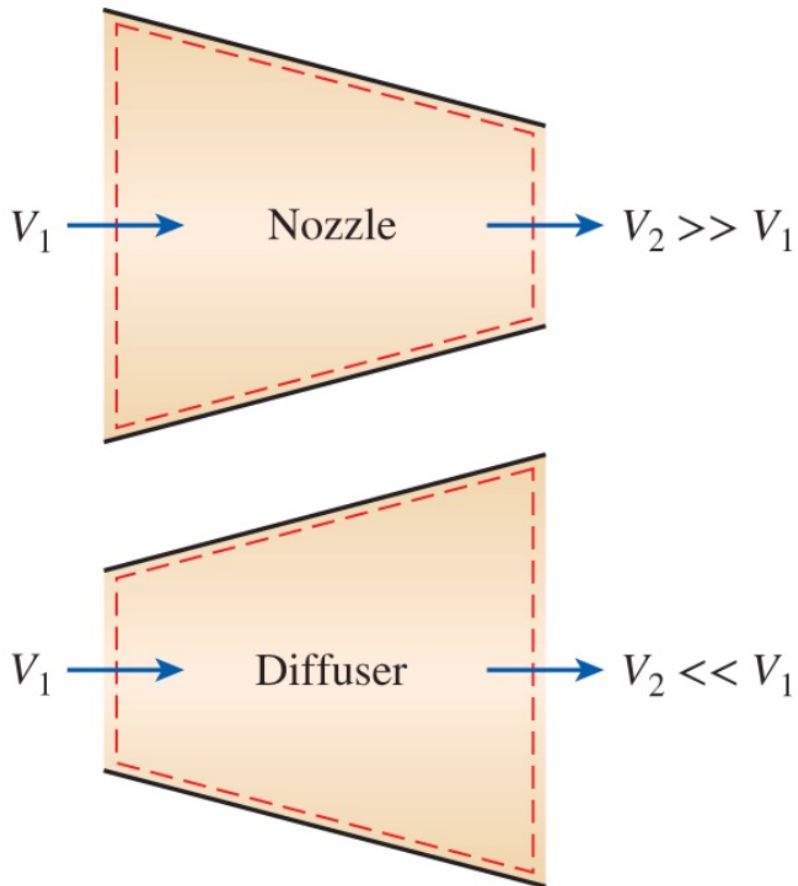

$$\dot{Q} \cong 0$$

$$\dot{W} = 0 \text{ (most times)}$$

$$\Delta pe \cong 0$$

$$\Delta ke \neq 0$$

SOME STEADY-FLOW ENERGY DEVICES

Some Steady-Flow Energy Devices

- **Throttling valves**

- ❑ Throttling valves are any kind of flow-restricting devices that cause a significant pressure drop in the fluid (e.g., valves, capillary tubes, porous plugs)
- ❑ Unlike turbines, they produce a pressure drop without involving any work
- ❑ The pressure drop in the fluid is often accompanied by a large drop in temperature, and for that reason throttling devices are commonly used in refrigeration and air-conditioning applications



(a) An adjustable valve



(b) A porous plug



(c) A capillary tube

Some Steady-Flow Energy Devices

- Throttling valves

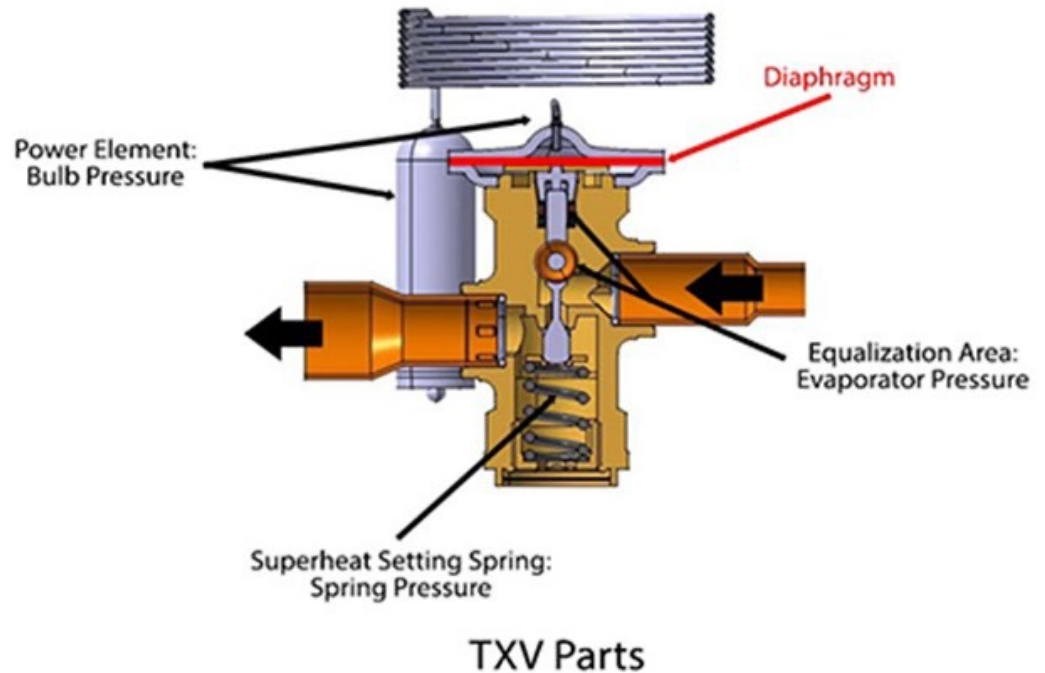
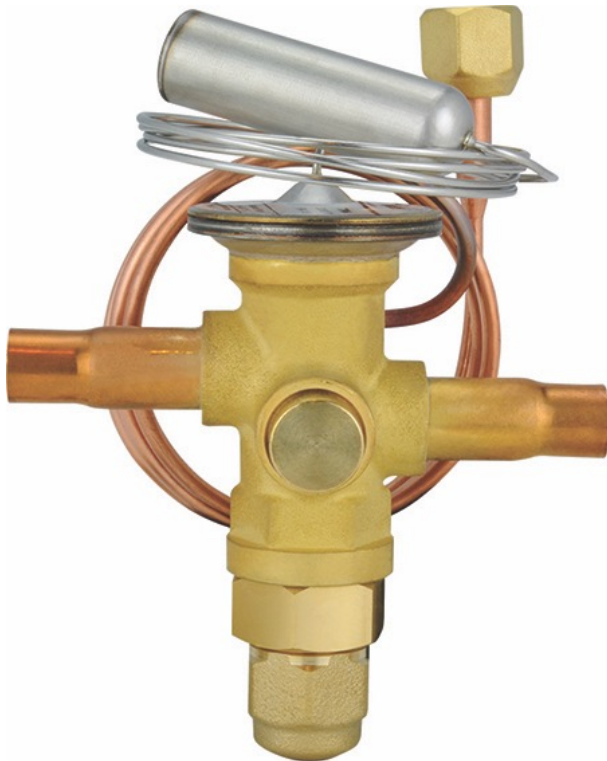

Some Steady-Flow Energy Devices

- **Throttling valves**

- They are usually small, the process can be adiabatic ($q \cong 0$)
- No work is done ($w \cong 0$)
- $\Delta pe \cong 0$
- $\Delta ke \cong 0$

$$h_2 \cong h_1 \quad (\text{Isenthalpic device})$$

$$u_1 + P_1 v_1 = u_2 + P_2 v_2$$

Internal energy + Flow energy = Constant

Some Steady-Flow Energy Devices

- **Throttling valves**

- In case of an ideal gas, $h = h(T)$, and thus the temperature has to remain constant during a throttling process:

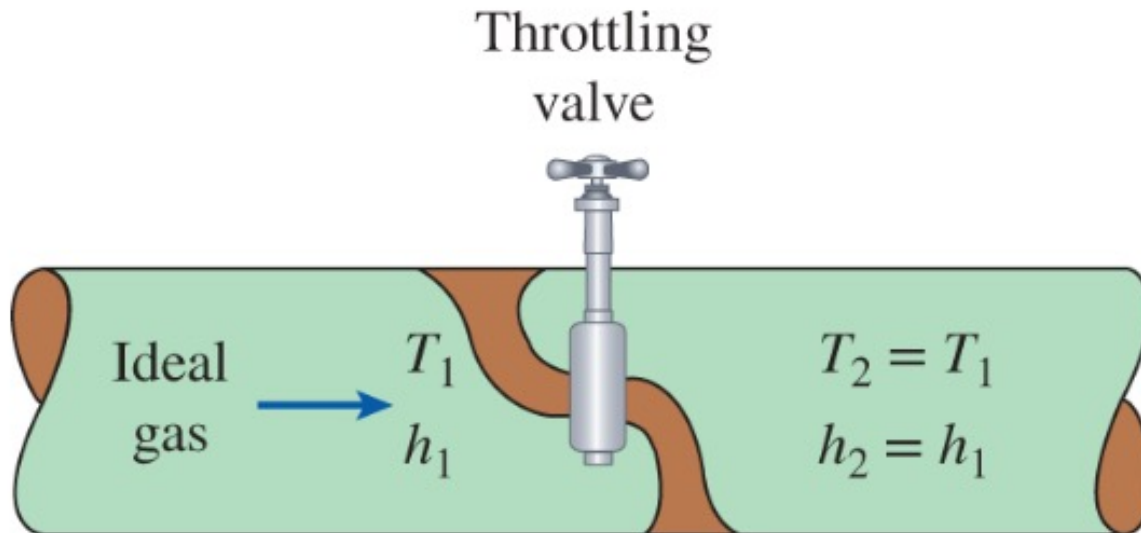

CLASS ACTIVITY

Class Activity

- Refrigerant-134a enters the capillary tube of a refrigerator as saturated liquid at 0.8 MPa and is throttled to a pressure of 0.12 MPa. Determine the quality of the refrigerant at the final state and the temperature drop during this process

Class Activity

- Solution:

At inlet:
$$\left. \begin{array}{l} P_1 = 0.8 \text{ MPa} \\ \text{sat. liquid} \end{array} \right\} \rightarrow \begin{array}{l} T_1 = T_{\text{sat}} @ 0.8 \text{ MPa} = 31.31 \text{ }^\circ\text{C} \\ h_1 = h_f @ 0.8 \text{ MPa} = 95.48 \text{ kJ/kg} \end{array} \quad \text{(Table A-12)}$$

TABLE A-12

Saturated refrigerant-134a—Pressure table

Press., P kPa	Sat. temp., T_{sat} °C	Specific volume, m ³ /kg		Internal energy, kJ/kg			Enthalpy, kJ/kg			
		Sat. liquid, v_f	Sat. vapor, v_g	Sat. liquid, u_f	Evap., u_{fg}	Sat. vapor, u_g	Sat. liquid, h_f	Evap., h_{fg}	Sat. vapor, h_g	Sat. liquid, s_f
700	26.69	0.0008331	0.029392	88.24	156.27	244.51	88.82	176.26	265.08	0.3323
750	29.06	0.0008395	0.027398	91.59	154.11	245.70	92.22	174.03	266.25	0.3434
800	31.31	0.0008457	0.025645	94.80	152.02	246.82	95.48	171.86	267.34	0.3540
850	33.45	0.0008519	0.024091	97.88	150.00	247.88	98.61	169.75	268.36	0.3641

Class Activity

- Solution:

$$\text{At exit} \quad \left. \begin{array}{l} P_2 = 0.12 \text{ MPa} \\ h_1 = h_2 \end{array} \right\} \rightarrow \begin{array}{l} h_f = 22.47 \text{ kJ/kg} \\ h_g = 236.99 \text{ kJ/kg} \end{array} \rightarrow T_{\text{sat}} = -22.32 \text{ }^\circ\text{C}$$

TABLE A-12

Saturated refrigerant-134a—Pressure table

Press., <i>P</i> kPa	Sat. temp., T_{sat} °C	Specific volume, m^3/kg		Internal energy, kJ/kg			Enthalpy, kJ/kg			
		Sat. liquid, v_f	Sat. vapor, v_g	Sat. liquid, u_f	Evap., u_{fg}	Sat. vapor, u_g	Sat. liquid, h_f	Evap., h_{fg}	Sat. vapor, h_g	Sat. liquid, s_f
60	-36.95	0.0007097	0.31108	3.795	205.34	209.13	3.837	223.96	227.80	0.0163
70	-33.87	0.0007143	0.26921	7.672	203.23	210.90	7.722	222.02	229.74	0.0326
80	-31.13	0.0007184	0.23749	11.14	201.33	212.48	11.20	220.27	231.47	0.0470
90	-28.65	0.0007222	0.21261	14.30	199.60	213.90	14.36	218.67	233.04	0.0600
100	-26.37	0.0007258	0.19255	17.19	198.01	215.21	17.27	217.19	234.46	0.0718
120	-22.32	0.0007323	0.16216	22.38	195.15	217.53	22.47	214.52	236.99	0.0926

Class Activity

- Solution:

$$h_f < h_2 < h_g$$

$$x_2 = \frac{h_2 - h_f}{h_{fg}} = \frac{95.48 - 22.47}{236.99 - 22.47} = 0.340$$

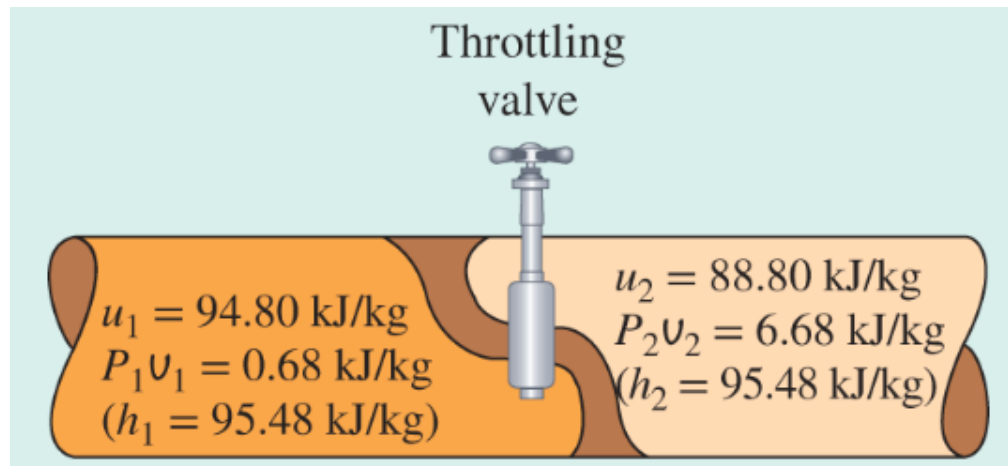

Some Steady-Flow Energy Devices

- **Mixing chambers**

- ❑ In engineering applications, mixing two streams of fluids is not a rare occurrence
- ❑ They are usually well-insulated ($q \cong 0$)
- ❑ Do not involve any kind of work ($w \cong 0$)
- ❑ Kinetic and potential energies negligible ($ke \cong 0$ & $pe \cong 0$)

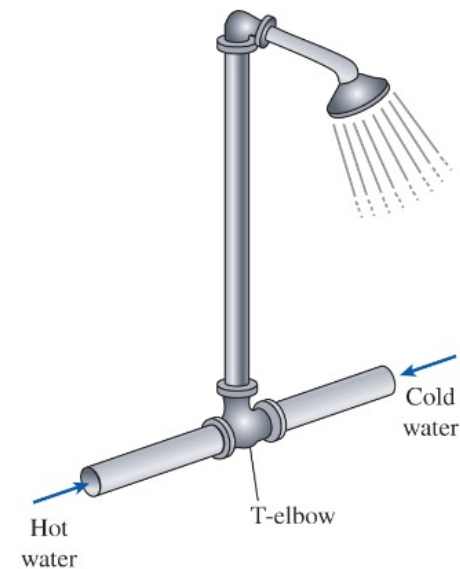
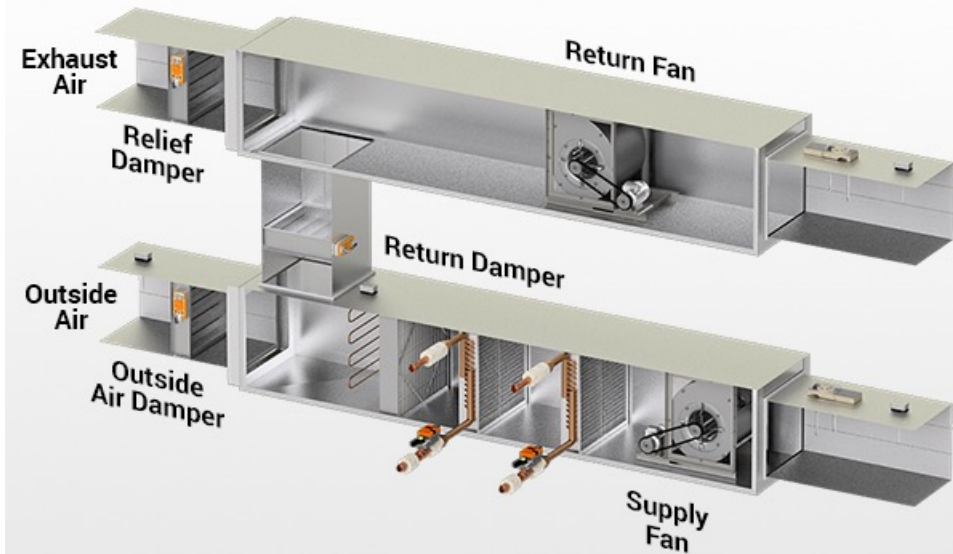

CLASS ACTIVITY

Class Activity

- Consider an ordinary shower where hot water at $140\text{ }^{\circ}\text{F}$ is mixed with cold water at $50\text{ }^{\circ}\text{F}$. If it is desired that a steady stream of warm water at $110\text{ }^{\circ}\text{F}$ be supplied, determine the ratio of the mass flow rates of the hot to cold water. Assume the heat losses from the mixing chamber to be negligible and the mixing to take place at a pressure of 20 psia .

Class Activity

- Solution (assumptions):
 1. Steady-flow ($\Delta m_{CV} = 0$ and $\Delta E_{CV} = 0$)
 2. The kinetic and potential energy changes are zero ($\Delta ke = \Delta pe = 0$)
 3. Heat losses from the system are negligible ($\dot{Q} \cong 0$)
 4. There is no work interaction involved

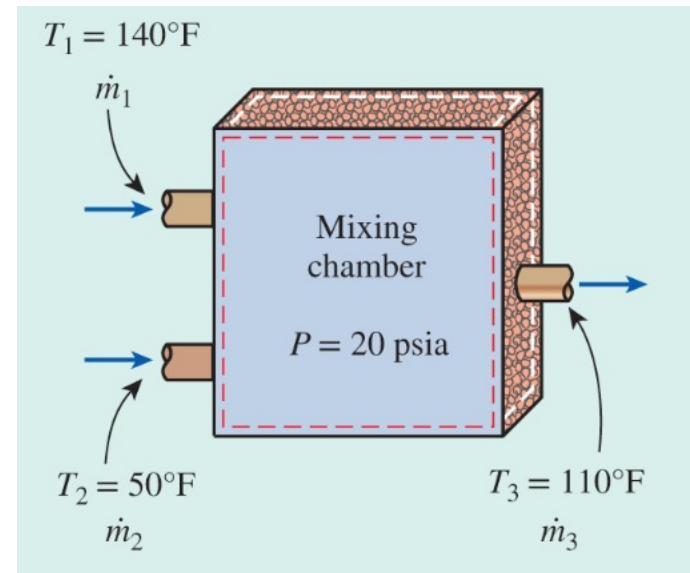

Class Activity

- Solution:

$$\dot{m}_{in} - \dot{m}_{out} = \frac{dm_{system}}{dt} = 0$$

$$\dot{m}_{in} = \dot{m}_{out} \rightarrow \dot{m}_1 + \dot{m}_2 = \dot{m}_3$$

$$\dot{E}_{in} - \dot{E}_{out} = \frac{dE_{system}}{dt} = 0$$

$$\dot{m}_1 h_1 + \dot{m}_2 h_2 = \dot{m}_3 h_3$$

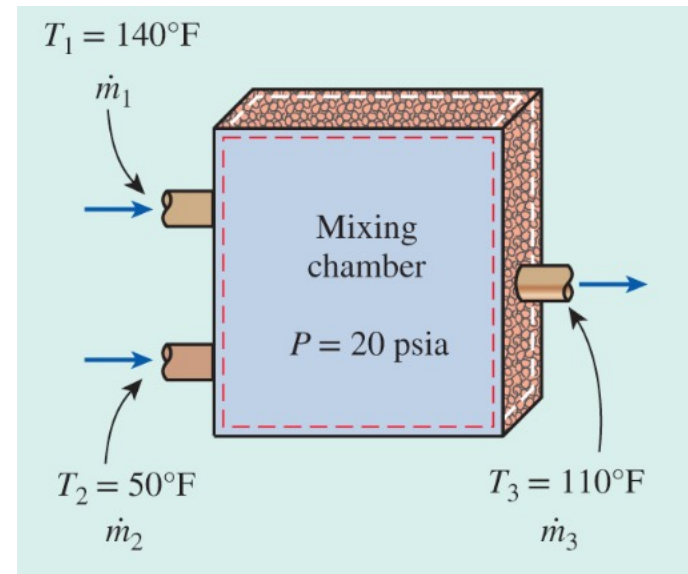

Class Activity

- Solution:

$$\dot{m}_1 h_1 + \dot{m}_2 h_2 = (\dot{m}_1 + \dot{m}_2) h_3$$

$$\left(\frac{\dot{m}_1}{\dot{m}_2}\right) h_1 + \left(\frac{\dot{m}_2}{\dot{m}_2}\right) h_2 = \left(\frac{\dot{m}_1}{\dot{m}_2} + \left(\frac{\dot{m}_2}{\dot{m}_2}\right)\right) h_3$$

$$y = \frac{\dot{m}_1}{\dot{m}_2}$$

$$y h_1 + h_2 = (y + 1) h_3$$

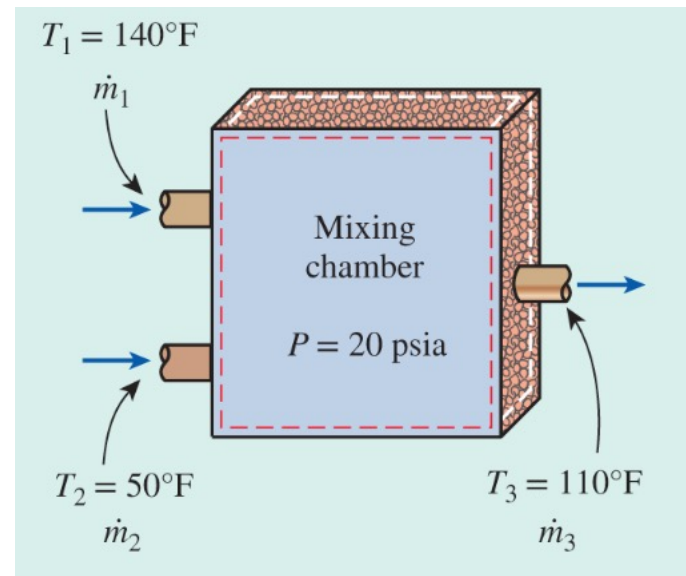

Class Activity

- Solution:
 - The saturation temperature of water at 20 psia is 227.92 °F. Since the temperature of all three steams are below this value ($T < T_{\text{sat}}$), the water in all three streams exists as a compressed liquid

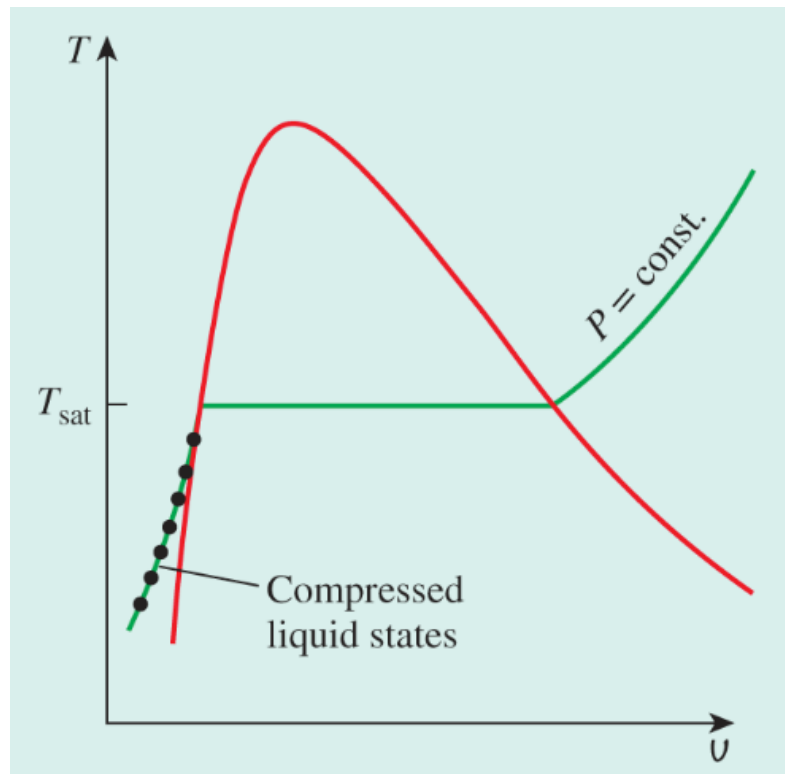

Class Activity

- Solution:

TABLE A-4E

Saturated water—Temperature table

Temp., <i>T</i> °F	Sat. press., <i>P</i> _{sat} psia	Specific volume, ft ³ /lbm		Internal energy, Btu/lbm			Enthalpy, Btu/lbm			Entropy, Btu/lbm · R		
		Sat. liquid, <i>v</i> _f	Sat. vapor, <i>v</i> _g	Sat. liquid, <i>u</i> _f	Evap., <i>u</i> _{fg}	Sat. vapor, <i>u</i> _g	Sat. liquid, <i>h</i> _f	Evap., <i>h</i> _{fg}	Sat. vapor, <i>h</i> _g	Sat. liquid, <i>s</i> _f	Evap., <i>s</i> _{fg}	Sat. vapor, <i>s</i> _g
32.018	0.08871	0.01602	3299.9	0.000	1021.0	1021.0	0.000	1075.2	1075.2	0.00000	2.18672	2.1867
35	0.09998	0.01602	2945.7	3.004	1019.0	1022.0	3.004	1073.5	1076.5	0.00609	2.17011	2.1762
40	0.12173	0.01602	2443.6	8.032	1015.6	1023.7	8.032	1070.7	1078.7	0.01620	2.14271	2.1589
45	0.14756	0.01602	2035.8	13.05	1012.2	1025.3	13.05	1067.8	1080.9	0.02620	2.11587	2.1421
50	0.17812	0.01602	1703.1	18.07	1008.9	1026.9	18.07	1065.0	1083.1	0.03609	2.08956	2.1256
55	0.21413	0.01603	1430.4	23.07	1005.5	1028.6	23.07	1062.2	1085.3	0.04586	2.06377	2.1096
60	0.25638	0.01604	1206.1	28.08	1002.1	1030.2	28.08	1059.4	1087.4	0.05554	2.03847	2.0940
65	0.30578	0.01604	1020.8	33.08	998.76	1031.8	33.08	1056.5	1089.6	0.06511	2.01366	2.0788
70	0.36334	0.01605	867.18	38.08	995.39	1033.5	38.08	1053.7	1091.8	0.07459	1.98931	2.0639
75	0.43016	0.01606	739.27	43.07	992.02	1035.1	43.07	1050.9	1093.9	0.08398	1.96541	2.0494
80	0.50745	0.01607	632.41	48.06	988.65	1036.7	48.07	1048.0	1096.1	0.09328	1.94196	2.0352
85	0.59659	0.01609	542.80	53.06	985.28	1038.3	53.06	1045.2	1098.3	0.10248	1.91892	2.0214
90	0.69904	0.01610	467.40	58.05	981.90	1040.0	58.05	1042.4	1100.4	0.11161	1.89630	2.0079
95	0.81643	0.01612	403.74	63.04	978.52	1041.6	63.04	1039.5	1102.6	0.12065	1.87408	1.9947
100	0.95052	0.01613	349.83	68.03	975.14	1043.2	68.03	1036.7	1104.7	0.12961	1.85225	1.9819
110	1.2767	0.01617	264.96	78.01	968.36	1046.4	78.02	1031.0	1109.0	0.14728	1.80970	1.9570

Class Activity

- Solution:

$$h_1 \cong h_f @ 140^\circ F = 107.99 \frac{Btu}{lbm}$$

$$h_2 \cong h_f @ 50^\circ F = 18.07 \frac{Btu}{lbm}$$

$$h_3 \cong h_f @ 110^\circ F = 78.02 \frac{Btu}{lbm}$$

Class Activity

- Solution:
 - Solving for y and substituting yields:

$$y = \frac{h_3 - h_2}{h_1 - h_3} = \frac{78.02 - 18.07}{107.99 - 78.02} = 2.0$$

$$y = \frac{\dot{m}_1}{\dot{m}_2} = 2 \quad \rightarrow \quad \dot{m}_1 = 2 \times \dot{m}_2$$

Some Steady-Flow Energy Devices

- **Heat Exchangers**

- ❑ Under steady operation, the mass flow rate of each fluid stream flowing through a heat exchanger remains constant
- ❑ Do not involve any kind of work ($w \cong 0$)
- ❑ Kinetic and potential energies negligible ($ke \cong 0$ & $pe \cong 0$)
- ❑ \dot{Q} depends!

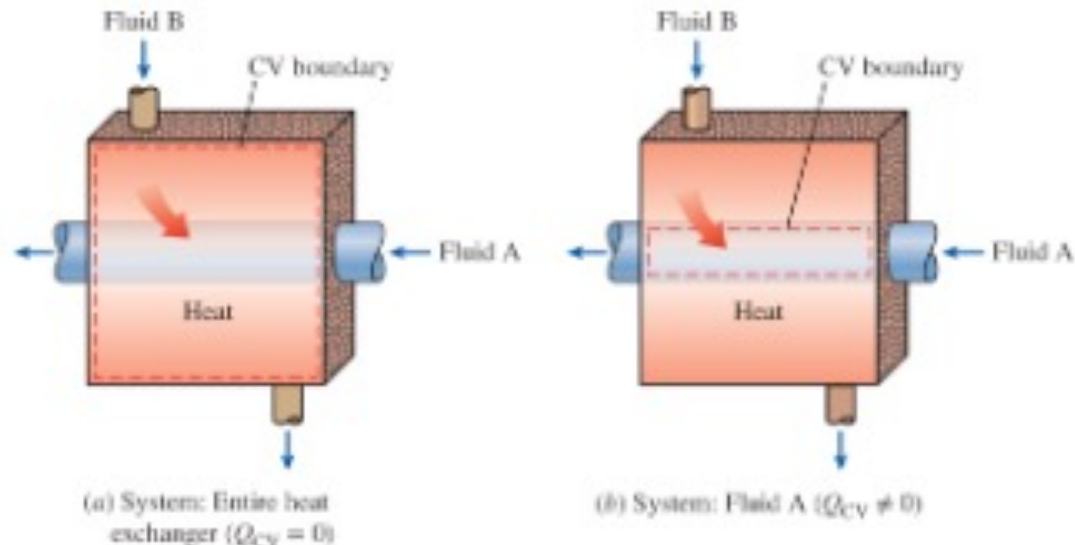

Some Steady-Flow Energy Devices

- Heat Exchangers

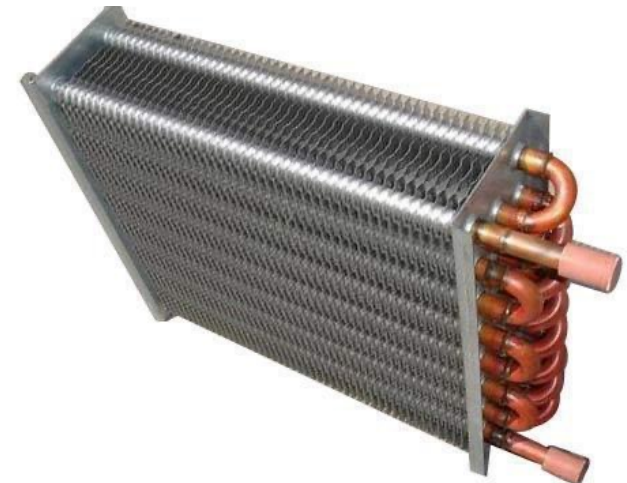
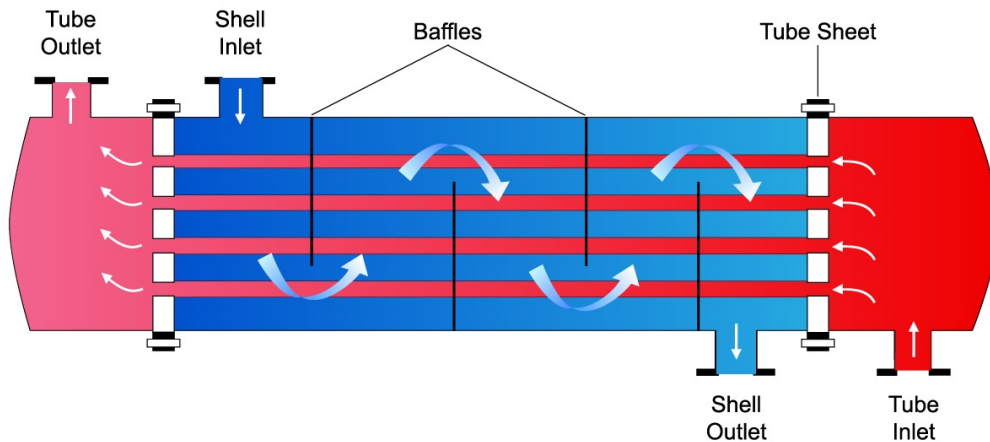
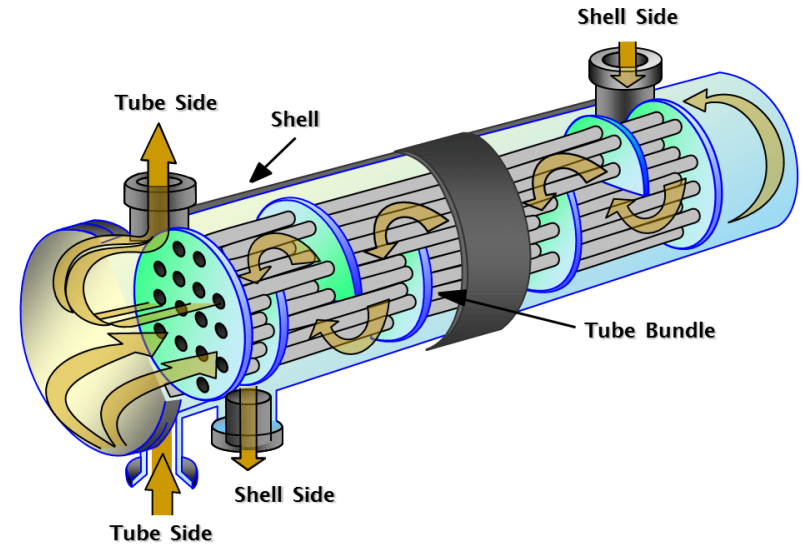
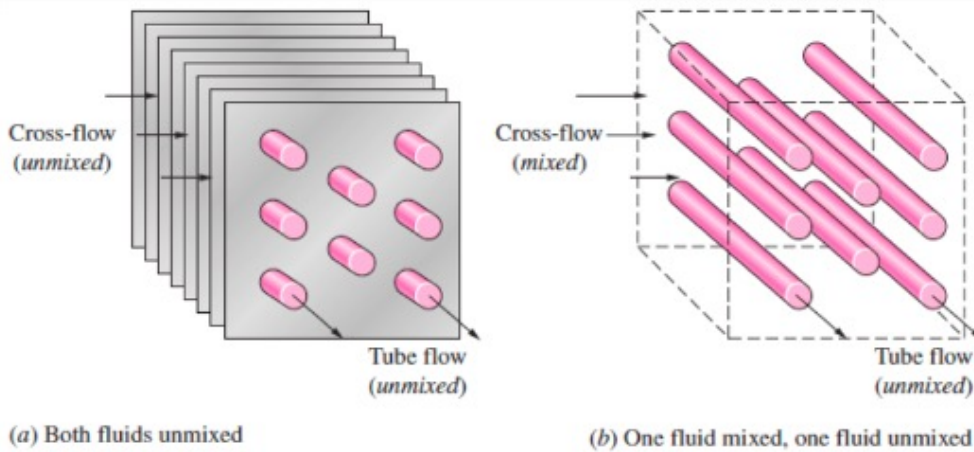

Class Activity

- Refrigerant 134a is to be cooled by water in a condenser. The refrigerant enters the condenser with a mass flow rate of 6 kg/min at 1 MPa and 70 °C (superheated) and leaves at 35 °C (compressed liquid). The cooling water enters at 300 kPa and 15 °C and leaves at 25 °C. Neglecting any pressure drops, determine:
 - a) The mass flow rate of the cooling water required
 - b) The heat transfer rate from the refrigerant to the water

Class Activity

- Solution (assumptions):
 1. Steady-flow ($\Delta m_{CV} = 0$ and $\Delta E_{CV} = 0$)
 2. The kinetic and potential energy changes are zero ($\Delta ke = \Delta pe = 0$)
 3. Heat losses from the system are negligible ($\dot{Q} \cong 0$)
 4. There is no work interaction involved

$$\dot{m}_{in} = \dot{m}_{out}$$

$$\dot{m}_1 = \dot{m}_2 = \dot{m}_w$$

$$\dot{m}_3 = \dot{m}_4 = \dot{m}_R$$

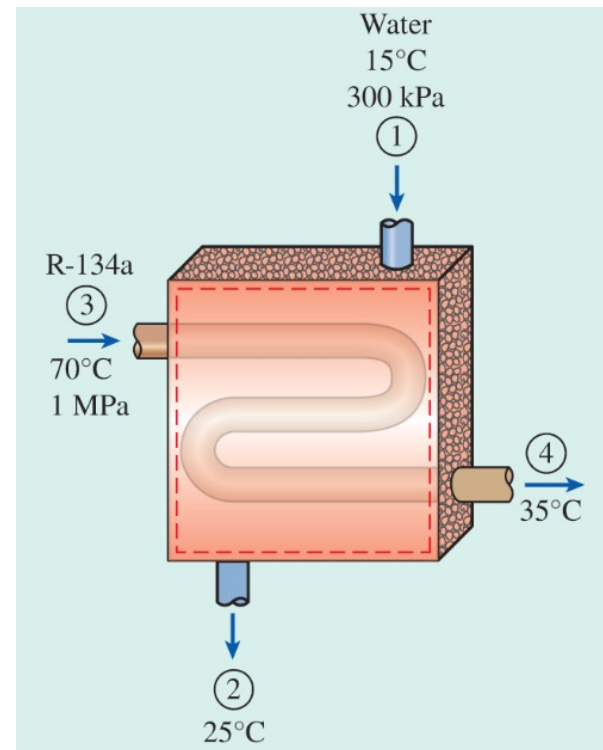

Class Activity

- Solution (a):

$$\dot{E}_{in} - \dot{E}_{out} = \frac{dE_{system}}{dt} = 0$$

$$\dot{E}_{in} = \dot{E}_{out}$$

$$\dot{m}_1 h_1 + \dot{m}_3 h_3 = \dot{m}_2 h_2 + \dot{m}_4 h_4$$

$$\dot{m}_w (h_1 - h_2) = \dot{m}_R (h_4 - h_3)$$

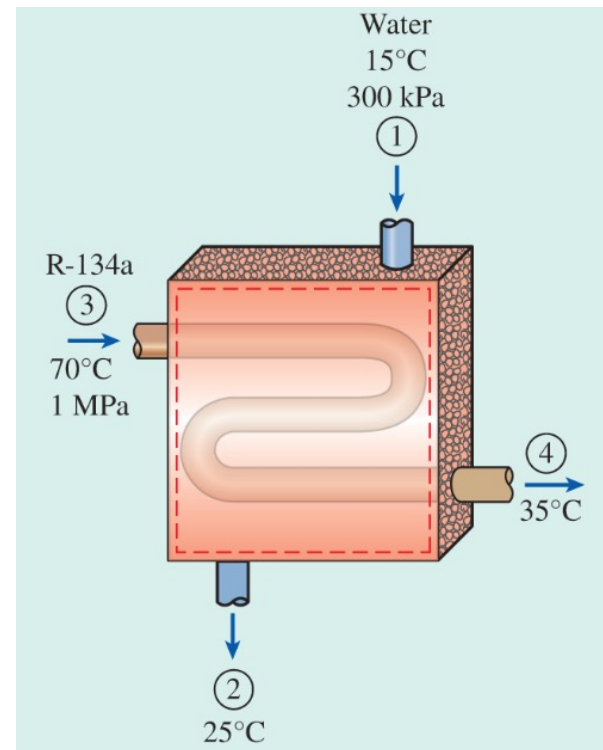

Class Activity

- Solution (a):
 - Water exits as a compressed liquid at both the inlet and exit since temperatures at both locations are below the saturation temperature of water at 300 kPa (113.53 °C)

TABLE A-5

Saturated water—Pressure table

Press., P kPa	Sat. temp., T_{sat} °C	Specific volume, m^3/kg		Internal energy, kJ/kg			Enthalpy, kJ/kg		
		Sat. liquid, v_f	Sat. vapor, v_g	Sat. liquid, u_f	Evap., u_{fg}	Sat. vapor, u_g	Sat. liquid, h_f	Evap., h_{fg}	Sat. vapor, h_g
250	127.41	0.001067	0.71873	535.08	2001.8	2536.8	535.35	2181.2	2716.5
275	130.58	0.001070	0.65732	548.57	1991.6	2540.1	548.86	2172.0	2720.9
300	133.52	0.001073	0.60582	561.11	1982.1	2543.2	561.43	2163.5	2724.9
325	136.27	0.001076	0.56199	572.84	1973.1	2545.9	573.19	2155.4	2728.6

Class Activity

- Solution (a):

TABLE A-4

Saturated water—Temperature table

Temp., T °C	Sat. press., P_{sat} kPa	Specific volume, m^3/kg		Internal energy, kJ/kg			Enthalpy, kJ/kg		
		Sat. liquid, v_f	Sat. vapor, v_g	Sat. liquid, u_f	Evap., u_{fg}	Sat. vapor, u_g	Sat. liquid, h_f	Evap., h_{fg}	Sat. vapor, h_g
0.01	0.6117	0.001000	206.00	0.000	2374.9	2374.9	0.001	2500.9	2500.9
5	0.8725	0.001000	147.03	21.019	2360.8	2381.8	21.020	2489.1	2510.1
10	1.2281	0.001000	106.32	42.020	2346.6	2388.7	42.022	2477.2	2519.2
15	1.7057	0.001001	77.885	62.980	2332.5	2395.5	62.982	2465.4	2528.3
20	2.3392	0.001002	57.762	83.913	2318.4	2402.3	83.915	2453.5	2537.4
25	3.1698	0.001003	43.340	104.83	2304.3	2409.1	104.83	2441.7	2546.5
30	4.2469	0.001004	32.879	125.73	2290.2	2415.9	125.74	2429.8	2555.6

$$h_1 \cong h_f @ 15 \text{ }^\circ\text{C} = 62.982 \frac{\text{kJ}}{\text{kg}}$$

$$h_2 \cong h_f @ 25 \text{ }^\circ\text{C} = 104.83 \frac{\text{kJ}}{\text{kg}}$$

Class Activity

- Solution (a):

$$\left. \begin{array}{l} P_3 = 1 \text{ MPa} \\ T_3 = 70 \text{ }^\circ\text{C} \end{array} \right\} \text{ (superheated)} \rightarrow h_3 = 303.87 \frac{\text{kJ}}{\text{kg}}$$

TABLE A-13

Superheated refrigerant-134a

T °C	ν m ³ /kg	u kJ/kg	h kJ/kg	s kJ/kg · K
P = 1.00 MPa ($T_{\text{sat}} = 39.37^\circ\text{C}$)				
Sat.				
40	0.020319	250.71	271.04	0.9157
50	0.020406	251.32	271.73	0.9180
60	0.021796	260.96	282.76	0.9526
70	0.023068	270.33	293.40	0.9851
80	0.024261	279.61	303.87	1.0160
90	0.025398	288.87	314.27	1.0459
100	0.026492	298.17	324.66	1.0749
110	0.027552	307.52	335.08	1.1032
120	0.028584	316.96	345.54	1.1309
130	0.029592	326.49	356.08	1.1580
140	0.030581	336.12	366.70	1.1847
150	0.031554	345.87	377.42	1.2110
160	0.032512	355.73	388.24	1.2369
170	0.033457	365.71	399.17	1.2624
180	0.034392	375.82	410.22	1.2876
190	0.035317	386.06	421.38	1.3125

Class Activity

- Solution (a):

$$\left. \begin{array}{l} P_3 = 1 \text{ MPa} \\ T_3 = 35 \text{ }^\circ\text{C} \end{array} \right\} \text{ (compressed liquid)} \rightarrow h_4 = h_f @ 35 \text{ }^\circ\text{C} = 100.88 \frac{\text{kJ}}{\text{kg}}$$

TABLE A-11

Saturated refrigerant-134a—Temperature table

Temp., T °C	Sat. press., P_{sat} kPa	Specific volume, m^3/kg		Internal energy, kJ/kg			Enthalpy, kJ/kg		
		Sat. liquid, ν_f	Sat. vapor, ν_g	Sat. liquid, u_f	Evap., u_{fg}	Sat. vapor, u_g	Sat. liquid, h_f	Evap., h_{fg}	Sat. vapor, h_g
34	863.11	0.0008535	0.023712	98.67	149.48	248.15	99.41	169.21	268.61
36	912.35	0.0008595	0.022383	101.56	147.55	249.11	102.34	167.19	269.53
38	963.68	0.0008657	0.021137	104.47	145.60	250.07	105.30	165.13	270.44

Class Activity

- Solution (a):

$$\dot{m}_w(62.982 - 104.83) \left(\frac{kJ}{kg} \right) = \left(6 \frac{kg}{min} \right) [100.88 - 303.87] \left(\frac{kJ}{kg} \right)$$

$$\dot{m}_w = 29.1 \frac{kg}{min}$$

Class Activity

- Solution (b):
 - We need to choose a control volume for this part: either water or the refrigerant. Here we chose water for no specific reason

$$\dot{E}_{in} - \dot{E}_{out} = \frac{d\dot{E}_{system}}{dt} = 0$$

$$\dot{E}_{in} = \dot{E}_{out}$$

$$\dot{Q}_{w,in} + \dot{m}_w h_1 = \dot{m}_w h_2$$

$$\dot{Q}_{w,in} = \dot{m}_w (h_2 - h_1) = \left(29.1 \frac{kg}{min} \right) = \left[(104.83) - (62.982) \frac{kJ}{kg} \right] = 1218 \frac{kJ}{min}$$

Some Steady-Flow Energy Devices

- **Pipe and Duct Flow**

- We countered the transport of liquids or gases in pipes and ducts is of great importance in many engineering applications (desired and undesired heat transfer)

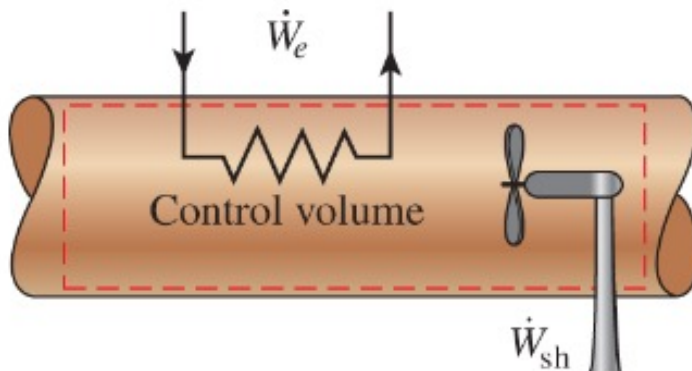
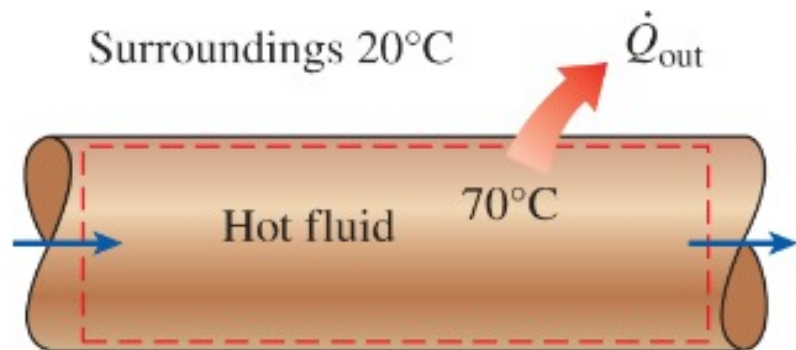

Some Steady-Flow Energy Devices

- **Pipe and Duct Flow**

- The velocities in pipe and duct flow are relatively low
- The kinetic energy changes are usually insignificant, especially when the pipe or duct diameter is constant, and the heating effects are negligible (could be important when cross section varies)
- Potential energy could be significant

CLASS ACTIVITY

Class Activity

- The electric heating systems used in many houses consist of a simple duct with resistance heaters. Air is heated as it flows over resistance wires. Consider a 15.kW electric heating system. Air enters the heating section at 100 kPa and 17 °C with a volume flow rate of 150 m³/min. If heat is lost from the air in the duct to the surroundings at a rate of 200 W, determine the exist temperature of air.

Class Activity

- Solution (assumptions):
 1. Steady-flow ($\Delta m_{CV} = 0$ and $\Delta E_{CV} = 0$)
 2. Air is an ideal gas since it is at a high temperature and low pressure relative to its critical point values
 3. The kinetic and potential energy changes are zero ($\Delta ke = \Delta pe = 0$)
 4. Constant specific heats at room temperature can be used for air

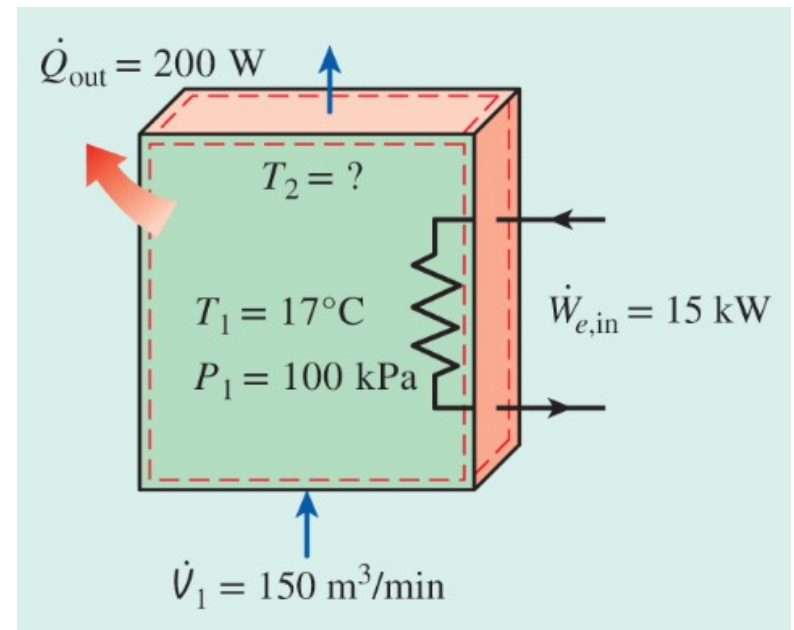

Class Activity

- Solution:

$$\dot{E}_{in} = \dot{E}_{out}$$

$$\dot{W}_{e,in} + \dot{m}h_1 = \dot{Q}_{out} + \dot{m}h_2$$

$$\dot{W}_{e,in} - \dot{Q}_{out} = \dot{m}c_p(T_2 - T_1)$$

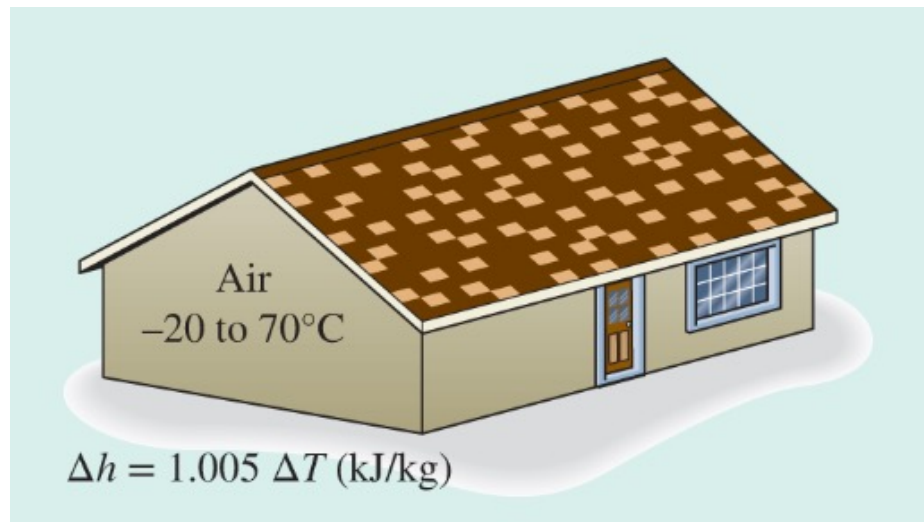

Class Activity

- Solution:

$$c_p = 1.005 \frac{\text{kJ}}{\text{kg} \cdot ^\circ\text{C}} \quad (\text{less than 0.5 percent for air in the range of } -20 \text{ to } 70 \text{ } ^\circ\text{C})$$

$$v_1 = \frac{RT_1}{P_1} = \frac{(0.287 \frac{\text{kPa} \cdot \text{m}^3}{\text{kg} \cdot \text{K}})(290\text{K})}{100 \text{ kPa}} = 0.832 \frac{\text{m}^3}{\text{kg}} \quad (\text{Ideal-gas})$$

$$\dot{m} = \frac{\dot{V}_1}{v_1} = \frac{150 \text{ m}^3/\text{min}}{0.832 \text{ m}^3/\text{kg}} (1 \text{ min}/60 \text{ s}) = 3.0 \text{ kg/s}$$

Class Activity

- Solution:

$$\left(15 \frac{\text{kJ}}{\text{s}}\right) - \left(0.2 \frac{\text{kJ}}{\text{s}}\right) = \left(3 \frac{\text{kg}}{\text{s}}\right) \left(1.005 \frac{\text{kJ}}{\text{kg} \cdot ^\circ\text{C}}\right) (T_2 - 17)^\circ\text{C}$$

$$T_2 = 21.9^\circ\text{C}$$

ENERGY ANALYSIS OF UNSTEADY- FLOW PROCESSES

Energy Analysis of Unsteady-Flow Processes

- During a steady-flow process, no changes occur within the control volume, so one does not need to be concerned about what is going on within the boundaries
- However, many processes involve change within the control volume with respect to time, which we call them *unsteady-flow* or *transient-flow* processes

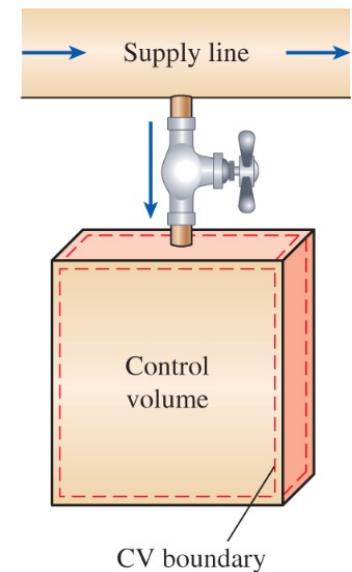

Energy Analysis of Unsteady-Flow Processes

- We deal with changes that occur over some time interval Δt instead of with the rate of changes
- At unsteady-flow system in some respects is similar to a closed system, except that the mass within the system boundaries does not remain constant during a process
- Steady-flow systems are fixed in space, size, and shape while unsteady-flow systems are not. They are usually stationary that is they are fixed in space, but they may involve moving boundaries and thus boundary work

Energy Analysis of Unsteady-Flow Processes

- Let's look at unsteady flow processes:

$$m_{in} - m_{out} = \Delta m_{system}$$

$$\Delta m_{system} = m_{final} - m_{initial}$$

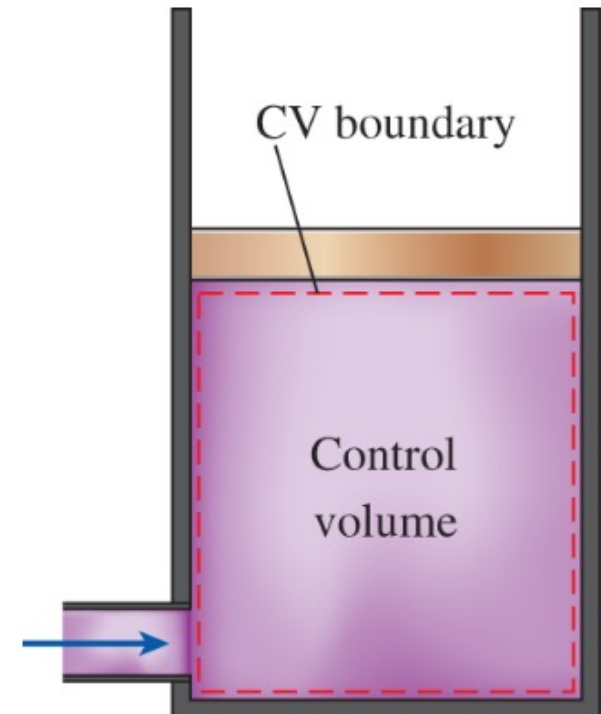

Energy Analysis of Unsteady-Flow Processes

- Let's look at unsteady flow processes and a few cases for mass change:

$$m_i - m_e = (m_2 - m_1)_{CV}$$

Energy Analysis of Unsteady-Flow Processes

- Let's look at unsteady energy balance:

$$E_{in} - E_{out} = \Delta E_{system}$$

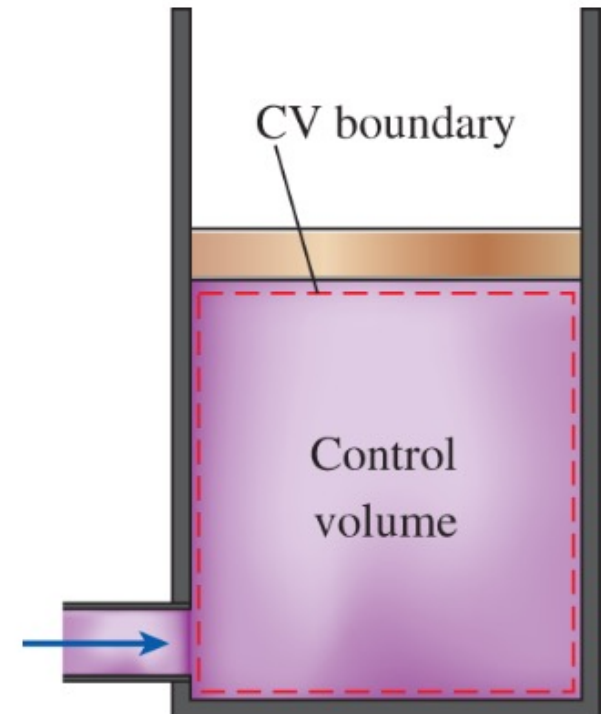

Energy Analysis of Unsteady-Flow Processes

- Let's look at unsteady flow process energy balance
 - It is difficult to solve
 - Sometimes we can use uniform-flow process

$$(Q_{in} + W_{in} + \sum_{in} m\theta) - (Q_{out} + W_{out} + \sum_{out} m\theta) = (m_2 e_2 - m_1 e_1)_{system}$$

Energy Analysis of Unsteady-Flow Processes

- Let's look at unsteady flow process energy balance
 - A few simplified cases (kinetic and potential energy changes associated with the control volume and fluid streams are negligible):

$$Q - W = \sum_{out} mh - \sum_{in} mh + (m_2u_2 - m_1u_1)_{system}$$

$$Q = Q_{net,in} = Q_{in} - Q_{out}$$

$$W = W_{net,in} = W_{in} - W_{out}$$

Energy Analysis of Unsteady-Flow Processes

- Let's look at unsteady flow process energy balance
 - If no mass enters or leaves the control during a process ($m_i = m_e = 0$ and $m_1 = m_2 = m$), the equation reduces to the energy balance relation for closed systems

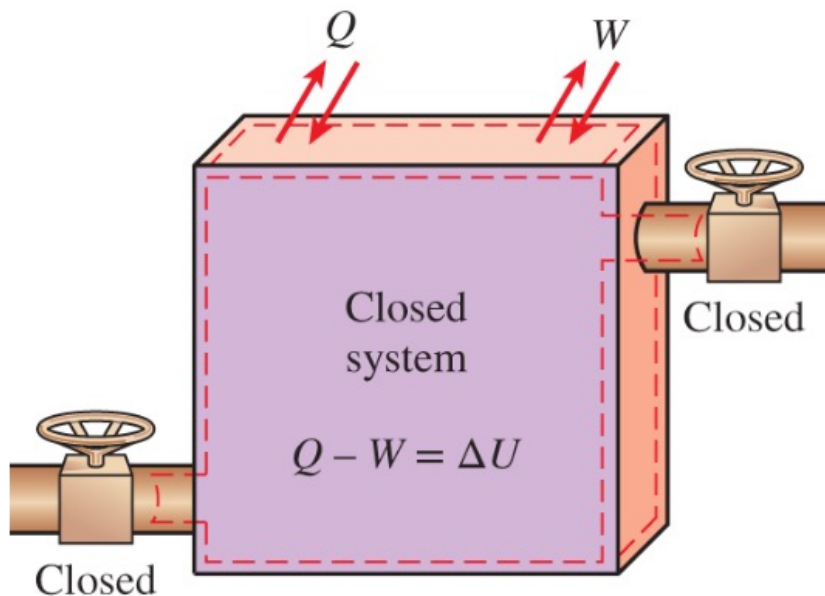

Energy Analysis of Unsteady-Flow Processes

- Let's look at unsteady flow process energy balance
 - It can also involve work:

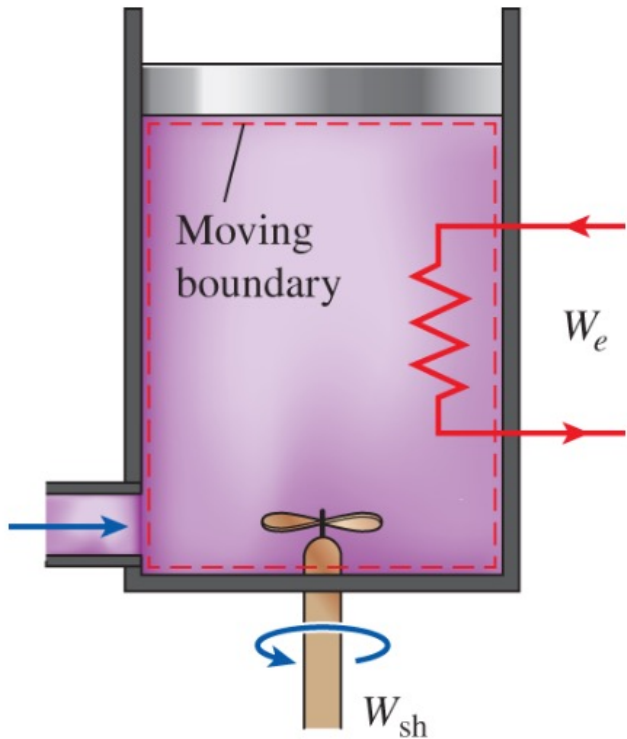

CLASS ACTIVITY

Class Activity

- A rigid, insulated tank that is initially evacuated is connected through a valve to a supply line that carries at 1 MPa and 300 °C. Now the valve is opened, and steam is allowed to flow slowly into the tank until the pressure reaches 1 MPa, at which the valve is closed. Determine the final temperature of the steam in the tank.

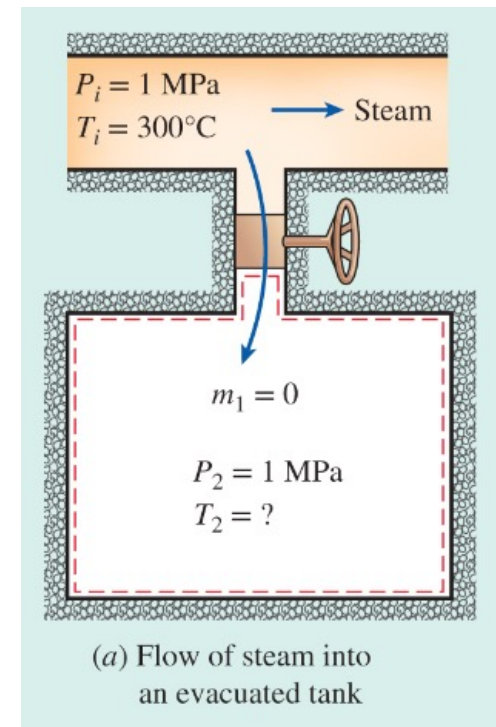

Class Activity

- Solution (assumptions):
 1. This process can be analyzed as a uniform-flow process since the properties of the steam entering the control volume remain constant during the entire process
 2. The kinetic and potential energies of the streams are negligible
 3. The tank is stationary and thus its kinetic and potential energy changes are zero ($\Delta KE = \Delta PE = 0$) and $\Delta E_{System} = \Delta U_{System}$
 4. There are no boundary, electrical, or shaft work interactions involved
 5. The tank is well-insulated and thus there is no heat transfer

Class Activity

- Solution:

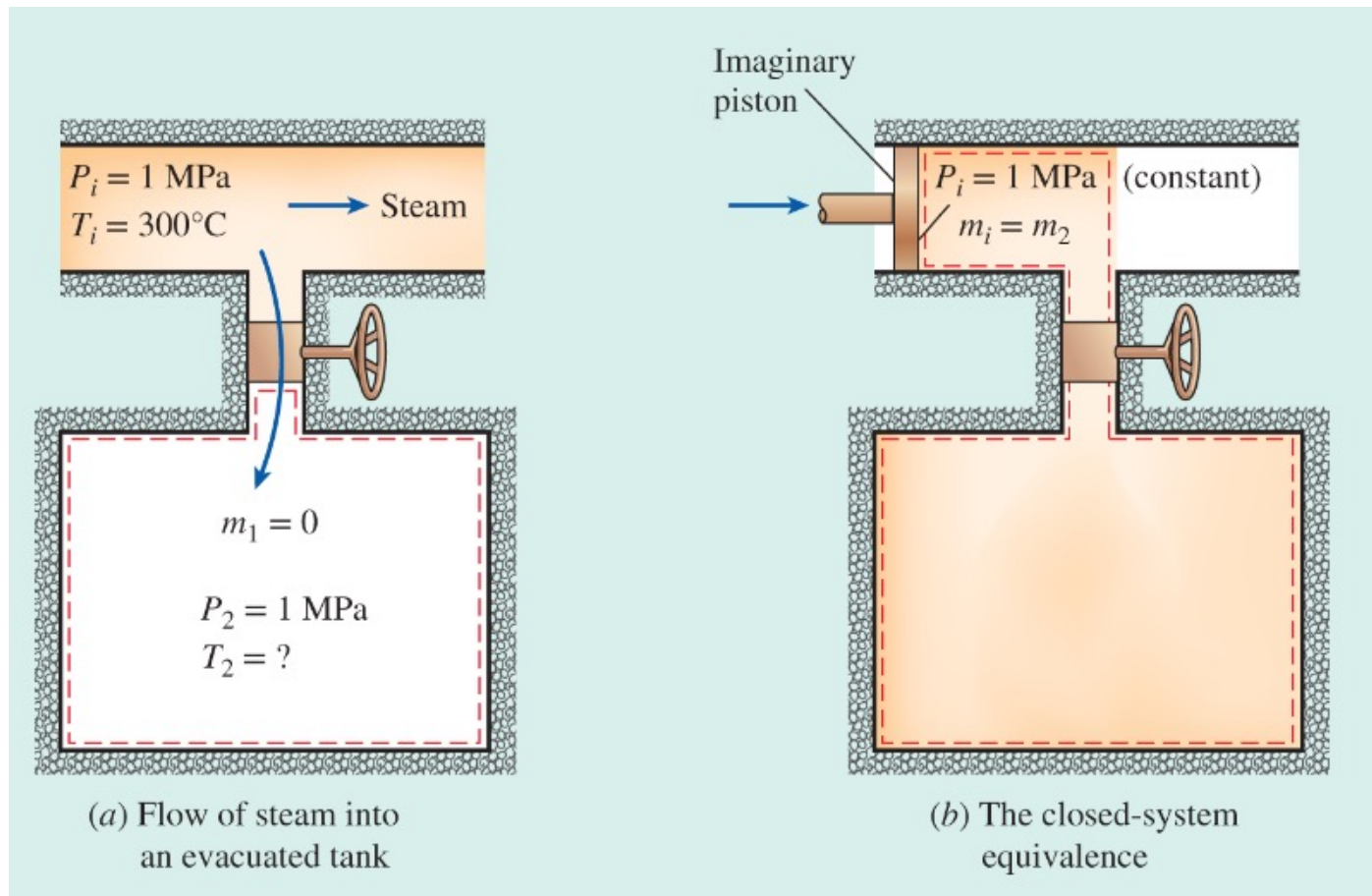

Class Activity

- Solution (mass balance):

$$m_{in} - m_{out} = \Delta m_{system} = m_2 - m_1$$

$$m_i = m_2$$

Class Activity

- Solution (energy balance):

$$E_{in} - E_{out} = \Delta E_{system}$$

$$m_i h_i = m_2 u_2$$

$$h_i = u_2$$

Class Activity

- Solution (finding states):

$$\left. \begin{array}{l} P_i = 1 \text{ MPa} \\ T_i = 300 \text{ }^\circ\text{C} \end{array} \right\} \rightarrow h_i = 3051.6 \frac{\text{kJ}}{\text{kg}}$$

$$h_i = 3051.6 \frac{\text{kJ}}{\text{kg}} = u_2$$

$$\left. \begin{array}{l} P_2 = 1 \text{ MPa} \\ h_2 = 3051.6 \frac{\text{kJ}}{\text{kg}} \end{array} \right\} \rightarrow T_2 = 456.1 \text{ }^\circ\text{C}$$

CLASS ACTIVITY

Class Activity

- An insulated 8 m³ rigid tank contains air at 600 kPa and 400 K. A valve is connected to the tank is now opened, and air is allowed to escape until the pressure inside drops to 200 kPa. The air temperature during the process is maintained constant by an electric resistance heater placed in the tank. Determine the electrical energy supplied to air during this process.

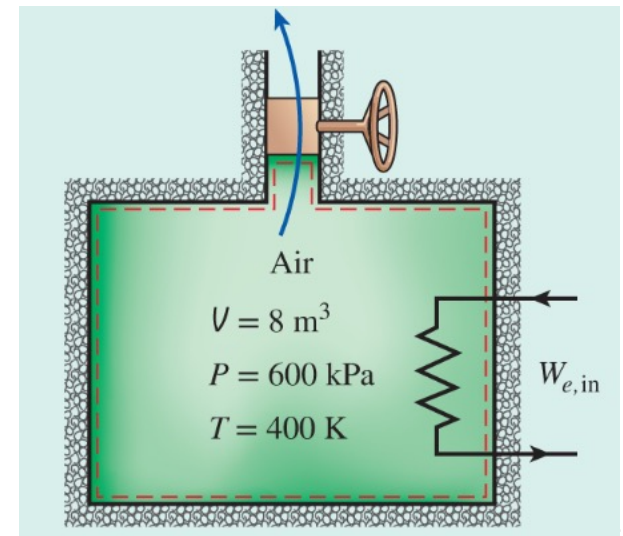

Class Activity

- Solution (assumptions):
 1. This process can be analyzed as a uniform-flow process since the properties of the steam entering the control volume remain constant during the entire process
 2. The kinetic and potential energies of the streams are negligible
 3. The tank is insulated, so heat transfer can be negligible
 4. Air is an ideal gas

Class Activity

- Solution (mass balance):

$$m_{in} - m_{out} = \Delta m_{system} = m_2 - m_1$$

$$m_e = m_1 - m_2$$

Class Activity

- Solution (energy balance):

$$E_{in} - E_{out} = \Delta E_{system}$$

$$W_{e,in} - m_e h_e = m_2 u_2 - m_1 u_1$$

Class Activity

- Solution (calculating masses):

$$R = 0.287 \frac{\text{kPa}\cdot\text{m}^3}{\text{kg}\cdot\text{K}} \quad (\text{Table A-1})$$

$$m_1 = \frac{P_1 v_1}{RT_1} = \frac{(600 \text{ kPa})(8 \text{ m}^3)}{(0.287 \frac{\text{kPa}\cdot\text{m}^3}{\text{kg}\cdot\text{K}})(400 \text{ K})} = 41.81 \text{ kg}$$

$$m_2 = \frac{P_1 v_1}{RT_1} = \frac{(200 \text{ kPa})(8 \text{ m}^3)}{(0.287 \frac{\text{kPa}\cdot\text{m}^3}{\text{kg}\cdot\text{K}})(400 \text{ K})} = 13.94 \text{ kg}$$

$$m_e = m_1 - m_2 = 41.81 - 13.94 = 27.87 \text{ kg}$$

Class Activity

- Solution (calculating masses):

$$\text{at } 400 \text{ K (Table A - 21): } \begin{cases} h_e = 400.98 \frac{\text{kJ}}{\text{kg}} \\ u_1 = u_2 = 286.16 \frac{\text{kJ}}{\text{kg}} \end{cases}$$

$$W_{e,in} = m_e h_e + m_2 u_2 - m_1 u_1$$

$$\begin{aligned} W_{e,in} &= (27.87 \text{ kg}) \left(400.98 \frac{\text{kJ}}{\text{kg}} \right) + (13.94 \text{ kg}) \left(286.16 \frac{\text{kJ}}{\text{kg}} \right) - (41.81 \text{ kg}) \left(286.16 \frac{\text{kJ}}{\text{kg}} \right) \\ &= 3200 \text{ kJ} = 0.889 \text{ kWh} \end{aligned}$$